**User's
Manual**

**Model SLBC
(Style E)
Batch Controller**

YEW SERIES BCS

IM 1B4E3-02E

Notices

■ Regarding This User's Manual

- (1) This manual should be passed on the end user. Keep at least one extra copy of the manual in a safe place.
- (2) Read this manual carefully and fully understand how to operate this product before you start operation.
- (3) This manual is intended to describe the functions of this product. Yokogawa Electric Corporation (hereinafter simply referred to as Yokogawa) does not guarantee that the functions will suit a particular purpose of the user.
- (4) Under absolutely no circumstances may the contents of this manual in part or in whole be transcribed or copied without permission.
- (5) The contents of this manual are subject to change without prior notice.
- (6) Every effort has been made to ensure accuracy in the preparation of this manual. Should any error or omissions come to your attention however, please contact your nearest Yokogawa representative or our sales office.

■ Regarding Protection, Safety, and Prohibition against Unauthorized Modification

- (1) In order to protect the product and the system controlled by it against damage and ensure its safe use, make certain that all of the instructions and precautions relating to safety contained in this manual are strictly adhered to. Yokogawa does not guarantee safety if products are not handled according to these instructions.
- (2) Be sure to use the spare parts approved by Yokogawa when replacing parts or consumables.
- (3) Modification of the product is strictly prohibited.
- (4) Reverse engineering such as the disassembly or decompilation of software is strictly prohibited.
- (5) No portion of the software supplied by Yokogawa may be transferred, exchanged, leased or sublet for use by any third party without the prior permission of Yokogawa.

■ Force Majeure

- (1) Yokogawa does not make any warranties regarding the product except those mentioned in the WARRANTY that is provided separately.
- (2) Yokogawa assumes no liability to any party for any loss or damage, direct or indirect, caused by the user or any unpredictable defect of the product.

CONTENTS

<i>Section</i>	<i>Title</i>	<i>Page</i>
1.	INTRODUCTION.	1-1
1-1.	Inspection.	1-1
1-2.	Scope of this Manual and Associated Manuals.	1-1
2.	GENERAL.	2-1
2-1.	Standard Specifications.	2-2
2-2.	Model and Suffix Codes.	2-5
2-3.	Options.	2-5
2-4.	Accessories.	2-5
3.	INSTALLATION.	3-1
3-1.	Wiring.	3-1
3-1-1.	Wiring Precautions.	3-2
4.	PRINCIPLES OF OPERATION.	4-1
4-1.	Totalizer Functions.	4-1
4-2.	Batch Functions.	4-2
4-3.	Flow Control Functions.	4-2
4-4.	Alarm Functions.	4-2
5.	OPERATION.	5-1
5-1.	Front- and Side-panel Features.	5-1
5-1-1.	Front Panel.	5-1
5-1-2.	Instrument Side Panel.	5-3
5-2.	Preparation of Data Label.	5-5
5-3.	Preparation for Operation.	5-5
5-3-1.	Check Special Parts are Installed.	5-5
5-3-2.	Setting Side Panel Switches.	5-5
5-3-3.	Setting Main Data.	5-6
5-3-4.	Setting Auxiliary Data.	5-7
5-3-5.	Simulation.	5-8
5-3-6.	Other Preparations.	5-8
5-4.	Operation and Handling.	5-8
5-4-1.	Batch Loading (Batch Operation).	5-8
5-4-2.	Fixed Flow PI Controller.	5-10
5-4-3.	Automatic Control.	5-11
5-4-4.	Transfer between Control Modes.	5-11
5-4-5.	Manual Mode.	5-11
5-4-6.	Resetting Cumulative Totalizer Value.	5-11
5-5.	Action to be Taken when FAIL or ALM Lamps Light.	5-12
5-5-1.	Action to be Taken when FAIL Lamp Lights.	5-12
5-5-2.	Action to be Taken when ALM Lamp Lights.	5-12
5-5-3.	Action to be Taken when ALM Lamp Flashes.	5-12
5-5-4.	Alarm (ALM) Codes, their Meanings and Control Actions when Abnormal.	5-12
6.	MAINTENANCE.	6-1
6-1.	Adjusting Zero Point of Control Output Indicator.	6-1
6-2.	Replacing Nameplate (Tag Label).	6-1
6-3.	Replacing Fuse.	6-1
6-4.	Replacing Data Memory Backup Battery.	6-2
WORKSHEET		WS 1B4E3-02E
Customer Maintenance Parts List		CMPL 1B4E3-03E
POWER SUPPLY TERMINALS for PANEL-MOUNTED INSTRUMENTS (for /HTB)		IM 1B4F1-11E

1. INTRODUCTION.

This instrument was thoroughly tested at the factory before shipment.

When the instrument is received, however, check visually for any external damage that occurred during shipment. Insure that all standard accessories are supplied.

1-1. Inspection.

Model and suffix codes are indicated on the nameplate (tuning panel) attached to the side of the instrument. Check them against the model and suffix codes given in section 2-2 to insure that the instrument meets your specifications.

If you have any questions about this instrument, please contact either your nearest Yokogawa Sales & Service Office or Yokogawa Electric Corporation, Tokyo, Japan.

1-2. Scope of this Manual and Associated Manuals.

This instruction manual covers handling, operating and simple maintenance procedures for the SLBC*E Batch Controller.

You should first read the following manuals, in order to fully understand the functions of the SLBC*E Batch Controller. You will then be able to fill out the data label on the side panel of the controller.

Please refer to the following manuals:

- ① TI 1B4E1-01E
“YewSeries BCS (Style E) Batch-Blending Control System Functions and Data Setting”.
- ② WS 1B4E3-02E “SLBC*E Data Sheet”.

2. GENERAL.

The SLBC* Batch Controller can be used on its own in Batch Loader loops, or can be used with the SLCC*E Blending Controller in high-resolution in-line batch blending systems. The controller functions include:

- Analog inputs/outputs, scaling, addition/subtraction of flow signals, compensation computations, instantaneous flow display, repeater for a flow signal, five different totalizers, flow program set unit with batch sequencer (batch sequence control switches are on the front panel); communications and self diagnostic functions are also provided as standard.
- This controller is easy to use and easy to engineer.

Figure 2-2-1 shows the front view of the SLBC*E Batch Controller.

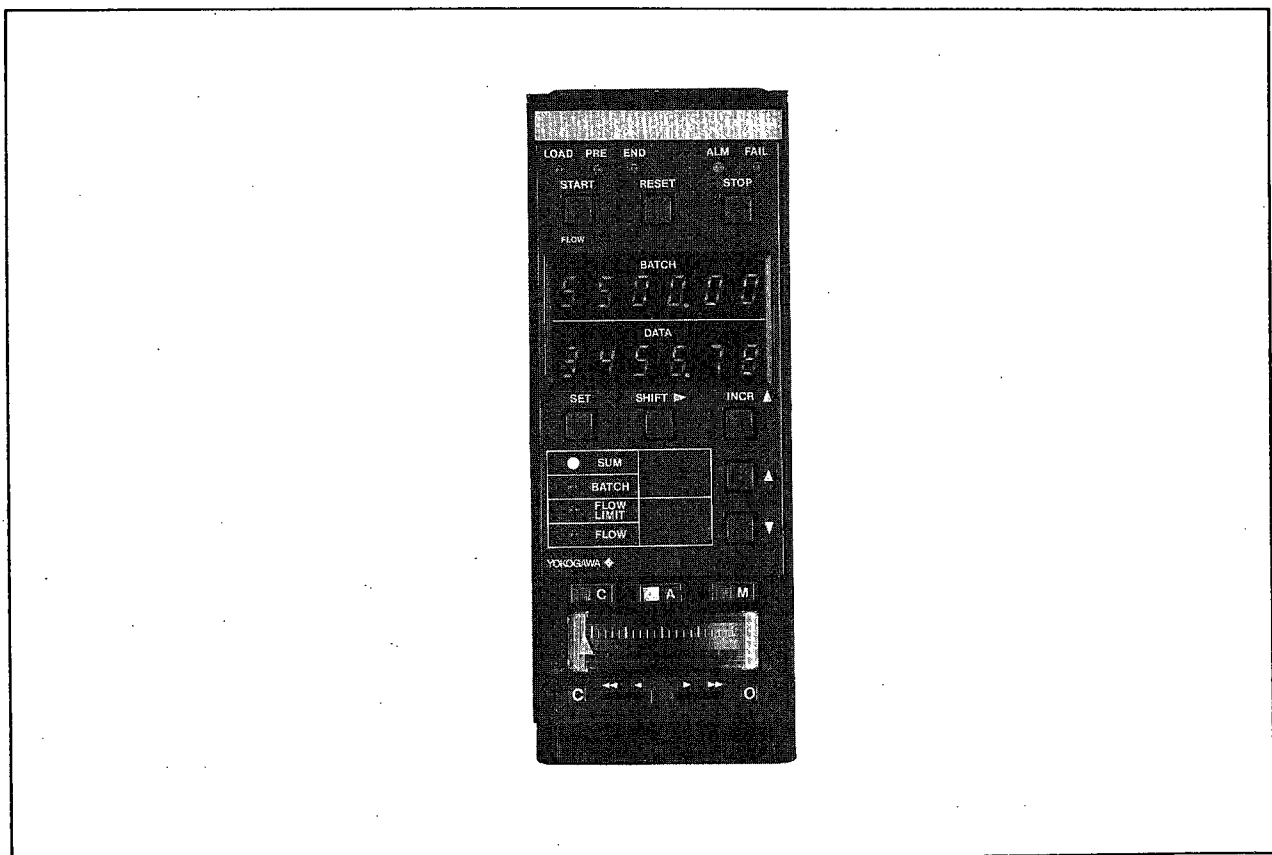

Figure 2-1-1. Front View of the SLBC*E.

2-1. Standard Specifications.

Input Signals

Process Variable Pulse Input Signal: 0 to 6 kHz, minimum pulse width 50 μ s, zero elevation not possible. Voltage or contact pulse input; two-wire or three-wire transmitter may also be used — distributor in SLBC supplies 12 V/24 V (switch-selectable). For two-wire transmitter, load resistance is switch selectable — 200 Ω , 520 Ω or 1 k Ω .

Voltage (Transition) Pulse: From two-wire or three-wire transmitter. Distributor voltage 12 V DC or 24 V DC \pm 10%, current up to 50 mA.

Voltage LOW Level (E_L): -1 V to +8 V DC.

Voltage HIGH Level (E_H): 3 V to 24 V DC.

Amplitude of Pulse Signal ($E_H - E_L$): At least 3 V.

Input Resistance: At least 10 k Ω .

Contact Pulse: Relay/switch contact or transistor switch.

Contact ON: Source resistance up to 200 Ω .

Contact OFF: Source resistance at least 100 k Ω .

Contact Rating: At least 30 V DC, 30 mA.

Filter for Contact Pulse Input: Switch-selectable, time constant 10 ms.

Auxiliary Pulse Input Signal (Added to/Subtracted from Process Variable), and Status/Mode Select

Contact Inputs: Auxiliary pulse input is 0 to 1 kHz, zero elevation not possible, minimum pulse width 350 μ s.

Status input minimum pulse width 220 ms.

Voltage (level) or contact signals.

Voltage (Level) Input:

Voltage LOW Level (E_L): -1 V to +1 V DC (status ON).

Voltage HIGH Level (E_H): 4.5 V to 25 V DC (status OFF).

Contact Input: Relay/switch contact or transistor switch.

Contact (Status) ON: Source resistance up to 200 Ω .

Contact (Status) OFF: Source resistance at least 100 k Ω .

Contact Rating: At least 5 V DC, 20 mA.

Analog Input Signals (Process Variable or Auxiliary Flow and Compensation Signals): 1 to 5 V DC, input resistance 1 M Ω .

Analog Input Conversion Accuracy: \pm 0.2% of span.

RTD Input Signal (for Temperature Compensation): (SLBC-301 only): JIS or DIN specification Pt 100 Ω 3-wire RTD, lead wire resistance up to 10 Ω /wire.

Temperature Compensation Accuracy: \pm 0.2% of span.

Burnout Function: Provided; scaleout time up to 60 s.

Output Signals

Pulse Output Signal (Flow Repeater or Demand Pulse Signal): Transistor contact signal, rating 30 V DC, 200 mA.

Frequency: 0 to 1 kHz; **Duty Cycle** 50% (for connecting to YewSeries BCS Instrument), or **Fixed Pulse Width** — selectable (one of 0.5, 1, 20, 33, 50 or 100 ms) — for electromechanical counter.

Status Output Signals (for flow signal input abnormal (missing/leakage), pre-batch and batch end alarms, reset and fail signals — five points): Transistor contact signals, rating 30 V DC, 200 mA.

Analog Output Signal (Flow Repeater Signal): 1 to 5 V DC, load resistance at least 2 k Ω .

Analog Control Output Signal: 4 to 20 mA DC, load resistance 0 to 750 Ω .

Analog Output Conversion Accuracy: \pm 0.3% of span.

Isolation

Contact (pulse/status) I/O signals are isolated from internal circuitry; analog signals are not. Pulse I/O signals are isolated from each other; status inputs, status outputs and analog I/O signals use separate common negative lines. Power supply is isolated from internal circuitry.

Input Processing Functions

Process variable and auxiliary flow inputs may be either voltage or pulse signals, compensation input may be either a voltage or RTD signal.

Auxiliary Flow Signal Processing:

Auxiliary flow signal can be added to or subtracted from process variable signal. Range of analog output (to PI algorithm, display and repeater) is adjustable.

Voltage Flow Signal Processing: Span setting (4-digit fixed point number) corresponding to input signal range of 1 to 5 V DC; low-input cutoff (for inputs under 1% of span) and square root function selectable.

Input Filters (for Process Variable Pulse Input and Auxiliary Pulse Input): First order lag filters, time constant adjustable 0 to 9999 s.

Totalizer Scale Factors: Scaler for pulse signal input (constant K number of pulses for every flow unit totalized). Totalizer scale factor for analog signal input. K (K_1 , K_2) are 5-digit fixed point numbers, of maximum value 32767.

Compensation Computations

Can compensate the process variable and auxiliary flow signals for liquid density changes with temperature.

SLBC has the following 4 ASTM compensation.

- Old ASTM No. D1250 (edit in 1952)
- New ASTM No. D1250 (edit in 1980)

for crude oils, fuels & solvents and lubricating oils.

Other types of compensation are also possible (see below).

Temperature Compensation:

Temperature unit is selectable (°C or °F).

Input Signal: Platinum RTD JIS '89 JPt 100 or JIS '89 Pt 100 (DIN Pt 100) or 1 to 5 V DC.

Temperature Range: For platinum RTD; -50 to +250°C.

For a 1 to 5 V DC signal: Arbitrary.

Computation Format: ASTM equation or general quadratic equation.

ASTM Equation: $V_0 = V [(1 + \alpha) f(\rho, t)]$
where $f(\rho, t) = \text{VCF}$

$$\text{VCF} = \frac{V_{15}}{V_t} = \frac{\rho_t}{\rho_{15}}$$

$$= \exp [-\alpha\gamma\Delta t (1.0 + 0.8 \alpha\gamma\Delta t)]$$

where VCF : Volume conversion coefficient (at 15°C)

V_{15} : Volume (m³) at 15°C

V_t : Volume (m³) at arbitrary temperature (t°C)

ρ_t : Density (t°C) (kg/m³)

ρ_{15} : Density (15°C) (kg/m³)

$\alpha\gamma$: Thermal expansion coefficient at 15°C (°C⁻¹)

Δt : Temperature difference [$\Delta t = t - 15$] (°C)

General Quadratic Equation:

$$V_0 = V[(1 + \alpha) \{1 + \beta(t - t_0) \times 10^{-2} + \gamma(t - t_0)^2 \times 10^{-6}\}]$$

V_0 : Volumetric flow at reference temperature t_0 .

V : Volumetric flow (process variable flow signal) at temperature t .

t_0 : Reference temperature (°C), $t_0 = 15^\circ\text{C}$ for ASTM.

t : Flow sensor temperature (°C).

α : Flow transmitter compensation coefficient, (-99.99 to +99.99).

β : First order compensation coefficient, (-99.99 to +99.99).

γ : Second order compensation coefficient, (-99.99 to +99.99).

General Compensation Computations:

Computation Format: $V_0 = V [(C_{\max} - C_{\min}) C + C_{\min}]$,
C ranges from 0 to 1 — its value corresponds to the compensation input signal: a voltage in the range 1 to 5 V DC. C_{\max} and C_{\min} are maximum and minimum compensation coefficients respectively, and may be set independently in the range 0 to 9999.

Flow Signal Repeater/Demand Pulse Output Function

Outputs pulse and analog signals corresponding to the flow signal process variable input (the instrument can also add or subtract an auxiliary flow signal input

— in this case, the span of analog output (to PI algorithm, display and repeater) is adjustable). Can output a demand pulse signal which corresponds to current set point in flow program.

Pulse Output: Output pulse rate may be scaled by a factor K' . K' (K_3, K_4) are 5-digit fixed point numbers, of maximum value 32767.

Pulse Output ON Time: Selectable — one of 0.5, 1, 20, 33, 50 or 100 ms — or duty cycle of 50% (for YewSeries BCS Instruments; up to ten may be connected in parallel with output).

Analog Output (Flow Signal Repeater Signal): 1 to 5 V DC.

Totalizer Functions

Five totalizers are built in — three 6-digit batch totalizers and two 8-digit (cumulative) totalizers:

- Batch flow totalizer (process variable only).
- Batch flow totalizer (process variable, with compensation computation).
- Batch flow totalizer (process variable, with auxiliary flow signal added to or subtracted from it, and compensation computation).
- Cumulative flow totalizer (process variable, with auxiliary flow signal added to or subtracted from it).
- Cumulative flow totalizer (process variable, with auxiliary flow signal added to or subtracted from it, and compensation computation).

Batch totalizer is reset after end of each batch by reset input signal or front panel reset pushbutton. Cumulative flow totalizer may be reset manually by entering other data for totalizer value.

Data Display and Data Setting Functions**Data Display:**

Upper display is batch loader setting, 6 digits.

Lower display is selectable data, 6 digits.

Selectable data (displayed in lower display) may be major data item or auxiliary data item:

Major Data Item: Displayed data type is indicated by lamp next to data item label on front panel. Value of batch flow totalizer (for process variable with auxiliary flow signal added to or subtracted from it, and compensation computation), batch setting, instantaneous flow high limit and instantaneous flow may be displayed.

Auxiliary Data Item: Displayed data type is indicated by code displayed in upper display. Auxiliary data includes the other four totalizer values, pre-batch alarm setting, program set parameters and control parameters. A table of data that may be displayed is on the instrument side panel.

Instantaneous Flow Display: 5-segment bar graph.

Data Setting:

Displayed Data Selection: Selected by push buttons.

One switch (on side panel) changes from major data display to auxiliary data display.

Data Setting: Uses push button switches. Data setting may be inhibited (disabled) by an inhibit/enable switch on the side panel.

SLBC Modes

The SLBC Batch Controller offers the following modes:

- Constant-flow manual unit, with ramp-up/ramp-down functions.
- Batch loader in a batch-blending control system (combination of batch set station and PI controller). (See batch sequence in table and flow set-point program in figure). Program is started by start status input or start pushbutton on front panel. Can be used as slave controller with master pacing input — input status changes (ON/OFF or OFF/ON) cause the output to ramp between high and low flow limits.
- Batch master station (like the SBSDD) — batch set-point program, output directly to slave controllers. (May be switched between master and batch loader modes by contact input).
- SPC or DDC modes are also possible.

Emergency Stop/Restart (see figure): Provided for batch loader modes (see above) using stop/start pushbuttons on front panel or external stop/start status inputs. Ramp change in output between high and low flow limits, step change in output between low flow limit and zero.

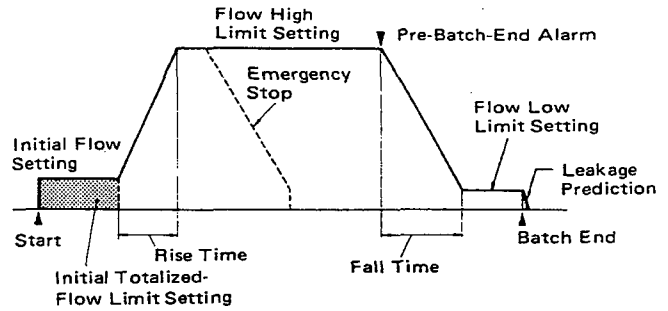

Control Functions

The SLBC contains a PI controller.

Control Modes: A (Auto) and M (Manual). (These correspond to SPC and DDC respectively in computer (remote setting) mode).

Auto Mode: PI control.

Proportional band 6.3 to 999.9%.

Integration time constant 1 to 9999 sec.

Manual Mode: Two speed operation.

Slow — 40 sec./full span change.

Fast — 4 sec./full span change.

Control Mode Transfer: Bumpless and balanceless A/M transfer.

Manipulated Variable Output Indication: Horizontal scale 39 mm long, one pointer, with two memory pointers and valve open/close direction marks.

Indicator Accuracy: ±2.5% of span.

Control Period: 0.2 sec.

Batch Functions

Batch Sequence:

Batch status	Status input/output	Lamp lit LOAD, PRE, END	Status output		
			Pre-batch	Batch	Reset
Start	Pushbutton or status input	LOAD lit	OFF to ON*	OFF to ON	—
Pre-batch	Batch-end pre-alarm output	PRE lit	ON to OFF	ON	—
Batch end	Batch end output	END lit LOAD off	OFF	ON to OFF	—
Reset	Pushbutton or status input	PRE, END off. LOAD*** flashing.	OFF	OFF	ON (momentary)
Stop	Pushbutton or status input	LOAD** PRE, END flashing.	OFF	ON to OFF***	—

*: Contact closes when the initial flow limit (see diagram below) is reached.

** : LOAD lamp flashes when STOP status input is turned OFF (STOP condition) or RESET status input is turned ON.

***: Contact opens after program ramps flow set point down to zero.

Batch Computation Period: 0.04 seconds.

Setpoint Program:

Alarm Functions

Detects loss of flow process variable input signal between the time flow should have reached high limit setting and pre-batch-end. ALM lamp lights, alarm output contact opens.

Leakage Detection: Detects leakage flow between batch end and reset. ALM lamp lights, alarm output contact opens.

Communication Functions

The SLBC can communicate (via LCS card in field control station/unit) with a central μXL/CENTUM CRT-display operator station and supervisory computer. Maximum length of (SCCD) cable to LCS card is 100 m (328 ft).

Data Transmitted: Instantaneous flow, batch flow totalizer value (process variable, with auxiliary flow signal added to or subtracted from it, and compensation computation), batch loader setting, initial flow setting, initial totalized flow limit setting, high flow limit setting, manipulated variable output, control mode, batch status, alarm status, compensation coefficients etc.

Data with Remote Setting: Batch loader setting, batch flow totalizer value (process variable, with auxiliary flow signal added to or subtracted from it, and compensation computation), initial flow setting,

initial totalized-flow limit setting, high flow limit setting, manipulated variable output (in manual or DDC modes), control mode, batch sequence status, compensation coefficients etc. Remote setting (from μ XL/CENTUM operator station or supervisory computer) can be disabled.

Computer/Auto/Manual (C/A/M) Mode Switches on SLBC Front Panel: Lamps in these switches indicate instrument mode. The mode (Computer/Auto/Manual) can be checked and changed by a supervisory computer or from a remote operator station. During SPC/DDC operation from a supervisory computer, only the "C" (Computer) lamp is lit. During local operation, or remote operation from the μ XL or CENTUM operator station, the "A" or "M" lamps are lit.

Mounting:

Flush panel mounting. Instruments are in housings, and may be mounted individually or side-by-side. Rear of instrument may be up to 75° below front (indicator zero may need readjustment).

Wiring:

Signal Wiring to/from the Field: ISO M4 size (4 mm) screws on terminal block.

Power and Ground Wiring:

100 V version: JIS C 8303 two-pin plug with earthing contact. (IEC A5-15, UL498).

220 V version: CEE 7 VII (CENELEC standard) plug. Power Cable Length: 30 cm (11.8 in).

Front Panel Finish: Dark green (Munsell 2.5GY 3/1).

Bezel: Aluminium diecast, black baked-enamel finish.

Housing: Open front, with connector for SPBD Portable Manual Station.

Housing Dimensions: 182.5 (H) × 87 (W) × 480 (D: depth behind panel) (mm) (7.2 × 3.4 × 18.9 in).

Weight:

Instrument body: 3.2 kg (7.0 lb) (excluding housing).

Housing: 2 kg (4.4 lb) (excluding mounting kit).

Normal Operating Conditions

Ambient Temperature: 0 to 50°C (32 to 122°F).

Ambient Humidity: 5 to 90% Relative Humidity (non-condensing).

Power Supply: Two versions, for "100 V" (standard) or "220 V" (option /A2ER). Both versions may use AC or DC, without change to the instrument:

Version	"100V"	"220V"
DC (polarity reversible)	20 to 130V	120 to 340V
AC (47 to 63Hz)	80 to 138V	138 to 264V

2-2. Model and Suffix Codes.

Model	Suffix codes	Style	Option codes	Description
SLBC	Batch controller with communication and compensation functions
Compensation Input	-2	1 to 5V DC
	-3	Pt 100Ω RTD
	01	Always 01
Style Code		*E	Style E
Option			/DL	With data sheet
Common Options			/A2ER	220V power supply ⁽¹⁾
			/PA	JIS '89 JPt 100 ⁽²⁾
			/PD	JIS '89 Pt 100 (DIN Pt 100) ⁽²⁾
			/MTS	With mounting kit
			/SCF-G□M	Bezel color change
			/HNS	Without housing
			/NPE	Nameplate engraving

(1) Specify /A2/NHS to order without housing.

(2) Specify only compensation input RTD.

2-3. Options.

/DL: With data set as per data sheet, and corresponding data label attached.

/A2ER: For "220 V version" power supply.

/PA: Compensation input JIS '89 JPt 100.

/PD: Compensation input JIS '89 Pt 100 (DIN Pt 100).

/MTS: Supplied with kit for individual mounting.

For mounting in groups, see GS 1B4F1-E.

/SCF-G□M: Mounting kit bezel color change from standard color (black). Choose color from set of optional colors (see GS 22D1F1-E). Specify color code in space □.

/NHS: No housing, plug-in instrument module only.

See GS 1B4F1-E to order housing separately.

/NPE: Letters engraved on front panel nameplate.

2-4. Accessories.

1A fuse, quantity one. Part No.: S9510VK

Engineering units label, one set. Part No.: E9712DL

Blank label, one set (for user filling) Part No.: E9712DS

Note: The fuse (S9510VK) is the dedicated fuse, Do not use it for other products.

3. INSTALLATION.

For general information regarding installation of this instrument, refer to the instruction manual "Installation of Panel-Mounting Instruments" (IM 1B4F1-01E).

3-1. Wiring.

The terminal board is located on the rear of the controller housing. Remove the cover of the terminal board, and connect external signal wires to the (M4 size) screw terminals. After wiring, be sure to replace the cover. (See Figures 3-1-1 and 3-1-2.)

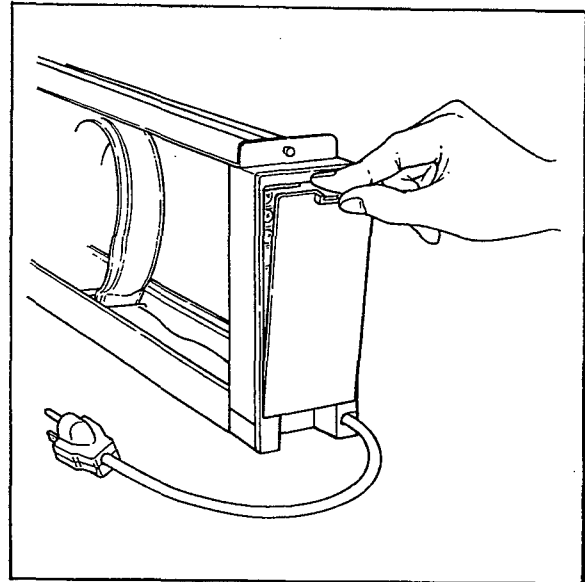

Figure 3-1-2. Terminal Cover.

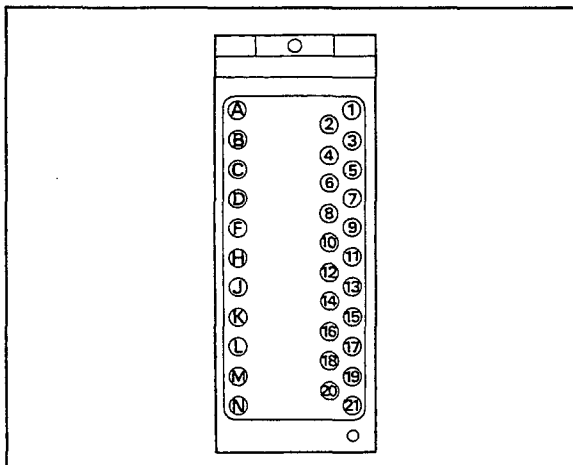

Figure 3-1-1. Terminal Layout.

Tables 3-1-1 shows the terminal designations and signals to be connected for the -201*E and -301*E versions of the controller.

Table 3-1-1. Terminal Connections.

Terminal Designation	Description	Terminal Designation	Description
1	Process variable input, pulse signal *1	17	+ Communication *2
2		18	- Communication *2
3		19	+ Auxiliary pulse-type flow signal input
4	B RTD input*3	20	- or mode select contact input
5	B RTD input*3	21	- Fail output (- terminal)
6	A RTD input*3	A	+ Manipulated output, 4 to 20mA DC
7	+ Process variable input, or auxiliary	B	- Manipulated output, 4 to 20mA DC
8	- flow input, 1 to 5V DC	C	+ Flow signal repeater (pulse output)
9	+ Master pacing input	D	- or demand pulse output
10	+ Start input	F	+ Reset output (+ terminal)
11	+ Reset input	H	
12	+ Stop input	J	+ Flow signal repeater (1 to 5V output)
13	- Common	K	- Flow signal repeater (1 to 5V output)
14	+ Pre-batch output	L	+ Alarm output
15	+ Batch end output	M	
16	- Common (and reset output) terminal	N	+ Fail output (+ terminal)

*1 Change wire connection according to the type of transmitter used.

Terminal Designation	Contact, or Voltage-Transition Pulse	2-wire Transmitter *5	3-wire Transmitter *5
1	+	-	Sig
2	-	+	-
3			+

*2: Use shielded twisted-pair cable (SCCD see GS 34B6T1-01E).

*3: For Model SLBC-301 only.

*4: For Model SLBC-201 only.

*5: 12V/24V distributor for transmitter built into SLBC.

3-1-1. Wiring Precautions.

- (1) Be sure to terminate all cable connections in solderless crimp-on lugs.
- (2) Each status and voltage input must be as per SLBC*E specifications. Note the limits on conductor resistance, voltage drop in conductors, and voltage (high/low) levels.
- (3) The fail and digital outputs are transistor contact signals (isolated from power supply and other internal circuitry). When connecting external devices, pay attention to the following: (See Figure 3-1-3.)
 - Observe correct polarity of status output terminals.
 - Most status outputs share a common negative terminal.
 - When connecting a relay or other such inductive device, connect a surge absorber (protective diode — Figure 3-1-3, CR circuit, etc.) in parallel with the load.
 - Note that status outputs cannot be connected directly to an AC circuit. Use a relay to switch an AC circuit.
 - Do not connect any load which exceeds the contact rating. (Max. 30V DC, 200 mA).
- (4) Use shielded twisted-pair SCCD cable for communication lines.

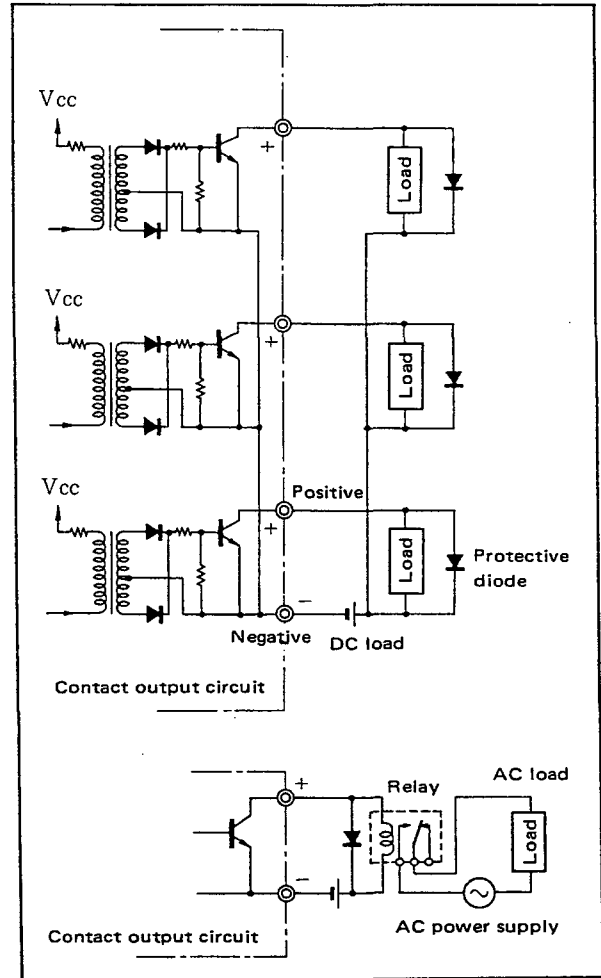

Figure 3-1-3. Connection of Contact Outputs.

4. PRINCIPLES OF OPERATION.

This chapter outlines some major features of the SLBC*E Batch Controller that are used daily in operating the system. For further details, read TI 1B4A3-01E "YewSeries BCS Batch-Blending Control System"

Refer to the SLBC*E functional block diagram in Figure 4-1-1.

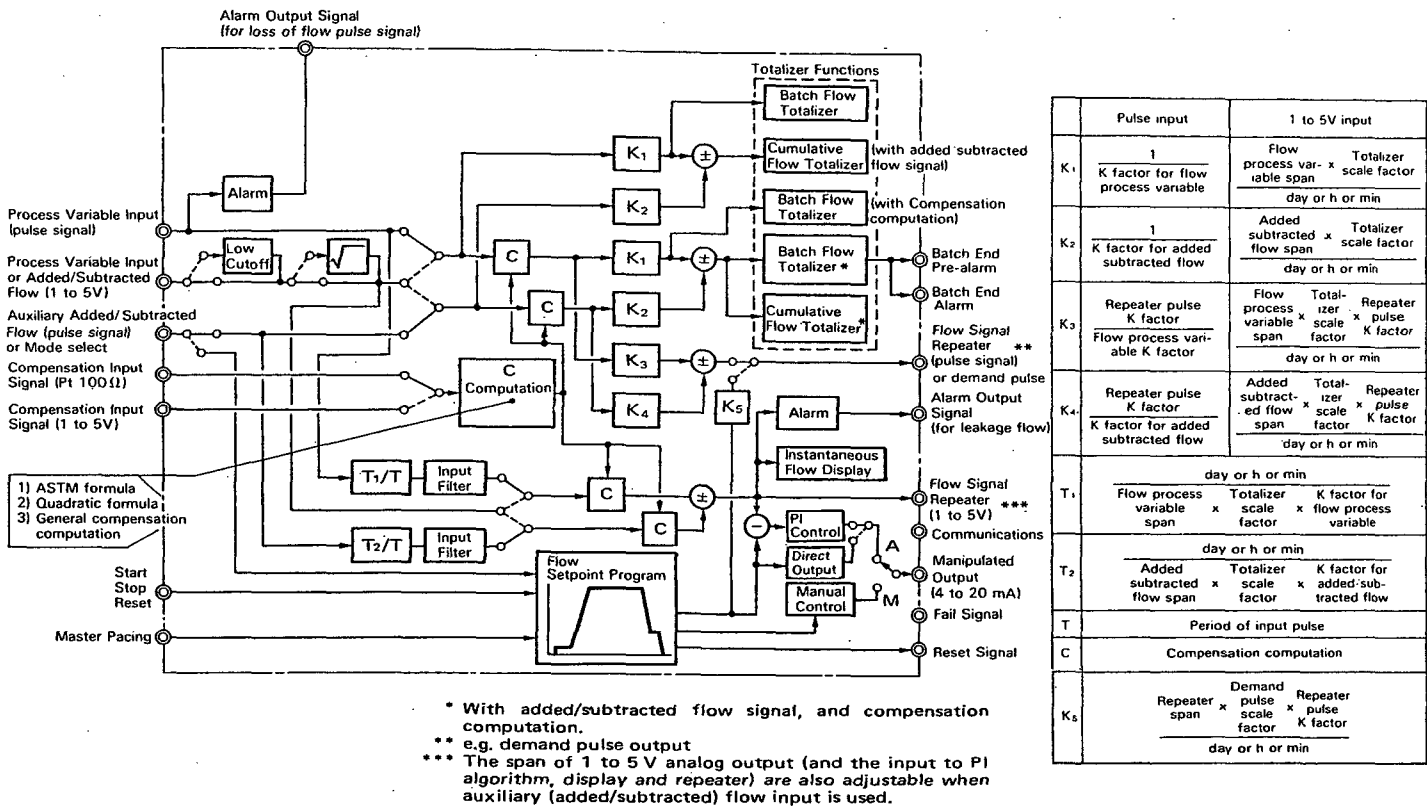

Figure 4-1-1. SLBC*E Functional Block Diagram.

4-1. Totalizer Functions.

Totalizers are essential in Batch-Blending Control. The SLBC*E permits the following five totalized values to be displayed. (See Figure 4-1-1.)

- (1) Batch flow totalizer value
Totalized value of uncompensated flow process variable signal.
- (2) Batch flow totalizer value (with compensation computation)
Totalized value of compensated flow process variable signal.
- (3) Batch flow totalizer value (with added/subtracted flow signal and compensation computation)

Totalized value for flow process variable after addition/subtraction of auxiliary input and compensation.

- (4) Cumulative flow totalizer value (with added/subtracted flow signal)
Cumulative totalizer value for uncompensated flow process variable after addition/subtraction of auxiliary input.
- (5) Cumulative flow totalizer value (with added/subtracted flow signal and compensation computation)
Cumulative totalizer value for flow process variable after addition/subtraction of flow signal and compensation computation.

The totalized values are classified into two types; batch totalizer values are reset after each batch, and cumulative totalizer values are not reset. The batch totalizer values are 6-digits long, and the cumulative totalizer values are 8-digits long and are displayed using the upper and lower sections of the display.

Of these five totalizer values, the batch flow totalizer value (with added/subtracted flow signal input, and compensation computation) is used as main data for batch processing, and is displayed as SUM on the front panel. The other four totalizer values are treated as auxiliary data.

4-2. Batch Functions.

Refer to 5-4-1 "Batch loading (Batch operation)".

4-3. Flow Control Functions.

This controller performs PI control so that the flow — with added/subtracted auxiliary signal and after compensation — agrees with the flow set value programmed by the batch sequence.

The PI constants necessary for control are set and indicated in the auxiliary data display.

<Major specifications>

Proportional band (P): 6.3 to 999.9%

Integral time (I): 1 to 9999 s.

Control mode transfer: A ↔ M transfer is bumpless and balanceless.

Direct/reverse action changeover provided.

4-4. Alarm Functions.

Alarm functions that are peculiar to SLBC*E are detection of missing pulse input and detection of leakage.

Figure 4-4-1 shows the relationship between the alarm functions and batch sequence.

(1) Detection of loss of pulse input.

If — between the time flow should have reached high limit setting and pre-batch-end — the process variable flow input signal level remains below 1% of span, the input signal is considered to be missing; the ALM lamp lights and the alarm output contact opens.

(2) Detection of leakage.

The leakage during the period between batch end and resetting is measured. If the leakage equals or exceeds a preset value (auxiliary data setting), the ALM lamp lights and the alarm output contact opens.

"Reset" resets the detected leakage value, but leakage detection continues until "Start".

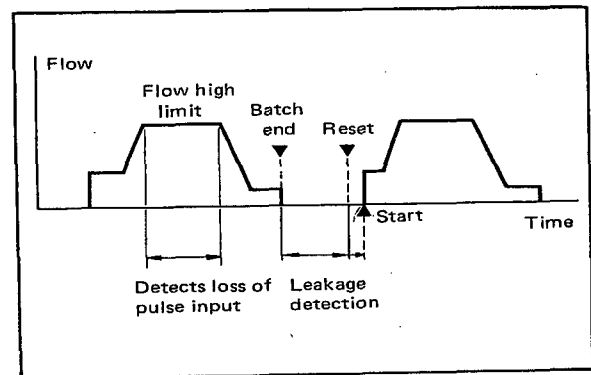

Figure 4-4-1.

5. OPERATION.

5-1. Front- and Side-Panel Features.

5-1-1. Front Panel.

Figure 5-1-1 shows the front panel of the SLBC*E Batch Controller.

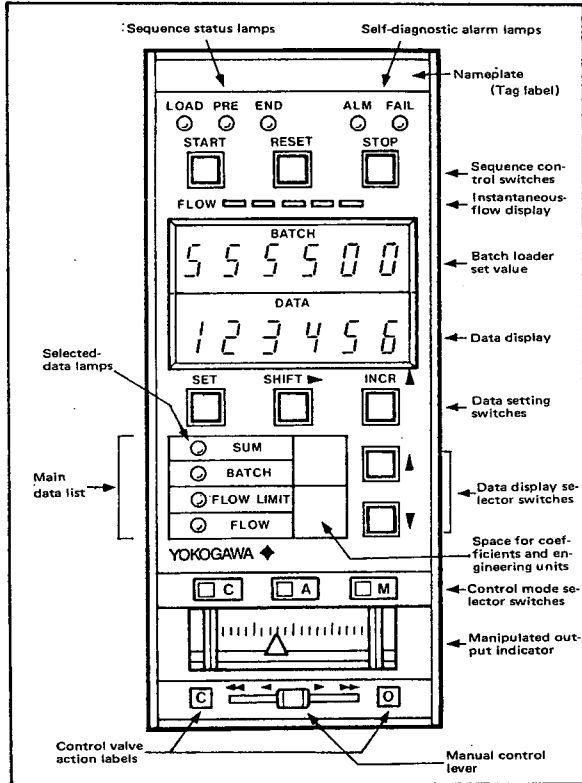

Figure 5-1-1. Front Panel.

- (1) Sequence status lamps (LOAD, PRE, END).
Display the status of the batch sequence.
- (2) Self-diagnostic alarm lamps.
FAIL lamp (red): Lights if the controller fails.
ALM lamp (yellow): Lights to indicate alarm status.
This lamp flashes if the data memory backup battery is not installed, or when its voltage is low.
- (3) Sequence control switches.
These switches are used to start, reset and stop the batch sequence. The batch sequence can be controlled by these switches or by contact inputs.
- (4) Instantaneous-flow display.
The instantaneous flow is displayed on a bar graph consisting of five LEDs.
- (5) Data display.
The data display is divided into two sections, upper and lower, each of which displays six digits.

Frequently-used “main data” (data items — such as set value and process variable value — shown in the main data list on the front panel), and “auxiliary data” (data items — such as computational constants and control constants — shown on the side panel data label) are displayed on this data display according to the setting of the main data/auxiliary data selector switch (FRONT P./SIDE P.) located on the side panel. (See item (6) of 5-1-2.)

During ordinary operation, set this selector switch to FRONT P. (main data). With this setting, the upper section of the display contains the batch set value, and the lower section of the display contains one of the main data items as selected by the data display selector switches ▲ ▼. A selected-data lamp lights to indicate which data item is selected. (See Figure 5-1-2.) To display auxiliary data items, set the FRONT P./SIDE P. selector switch to SIDE P. (auxiliary data). With this setting, the upper section of the display contains an auxiliary data item no., and the lower section contains the corresponding data. The desired item can be selected using the data display selector switches ▲ ▼. (See Figure 5-1-3.)

The lower data display section can be used for displaying data, and also for setting computational constants, control constants and other values.

- (6) Data setting switches ([SET], [SHIFT▶], [INCR▲]).

These switches are used for setting data.

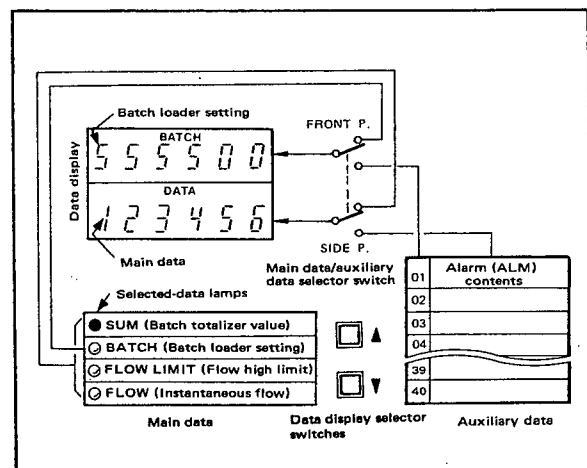

Figure 5-1-2. Functions of Data Display. (Main data display shown.)

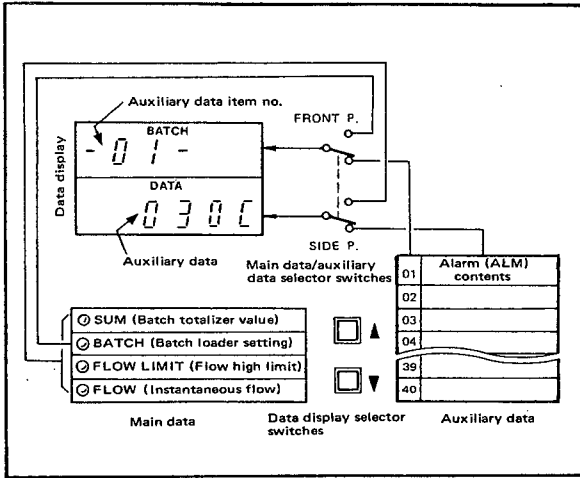

Figure 5-1-3. Functions of Data Display.
(Auxiliary data display shown.)

- (7) Data display selector switches (▲, ▼).
Used to select data to be displayed in the data display.
- (8) Main data list.
Contains the most-often-used data. A desired data item can be selected using the data display selector switches.
Main data:
SUM..... Batch totalizer value
BATCH..... Batch set value
FLOW LIMIT..... Flow high limit
FLOW..... Instantaneous flow
- (9) Selected-data lamps.
One of these lamps lights to indicate the main data item selected by the data display selector switches.

- (10) Space for displaying coefficients and engineering units.
The "coefficients/engineering-units label" provided as an accessory is attached here.
- (11) C/A/M control mode selector switches.
These switches select the control mode. The lamp inside the selected mode switch lights.
C mode: Automatic mode (batch control). The system may be monitored and settings may be changed from a supervisory computer.
A mode: Automatic mode (batch control).
M mode: Manual mode. The control output signal can be increased or decreased by the manual control lever.
- (12) Manipulated variable output indicator.
Indicates the current output signal.
Left end 4 mA DC; right end 20 mA DC.
- (13) Manual control lever.
Used for adjusting the control output signal of the controller in manual (M) mode.
Action:
Signal output decreases as lever is moved toward left.
Signal output increases as lever is moved toward right.
Rate of change:
◀, ▶ 40 s./full scale.
◀◀, ▶▶ 4 s./full scale.
Fine adjustment:
Momentary (approx. 0.2 s.) movement of the lever left ◀ or right ▶ from the neutral position changes the control signal by 0.1%.

5-1-2. Instrument Side Panel.

Figure 5-1-4 shows details of the SLBC*E side panel.

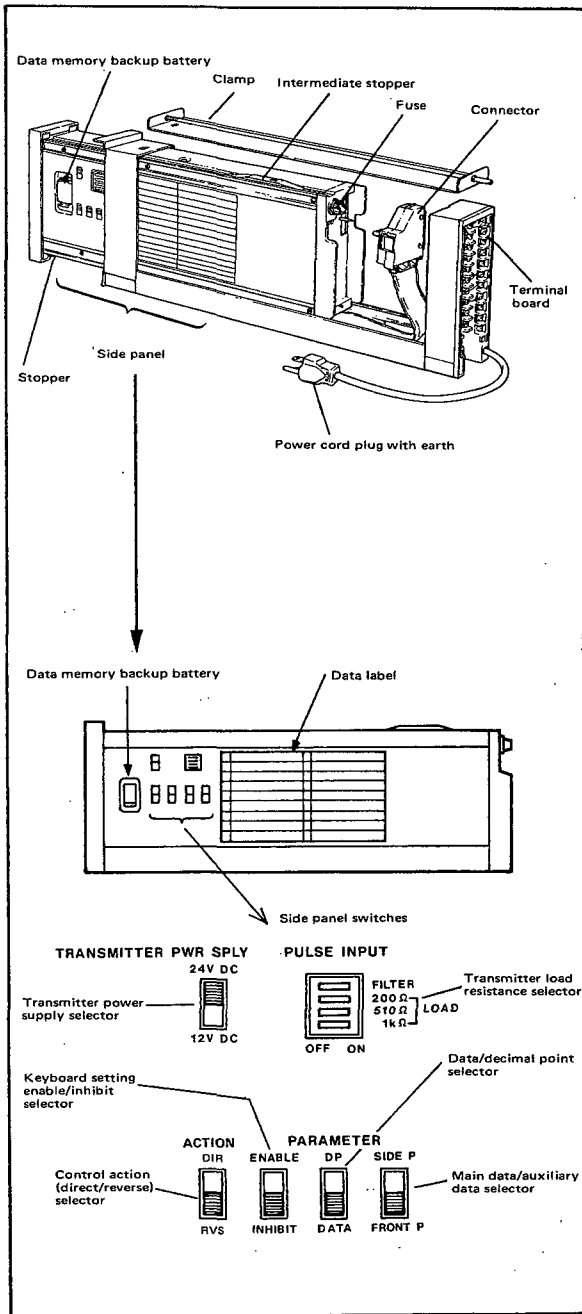

Figure 5-1-4. Details of Side Panel.

- (1) Transmitter power supply selector switch (TRANSMITTER PWR SPLY).

For pulse type process variable input signals (two-wire distributor type or three-wire distributor type, see Table 3-1-1, note *1) 12 or 24V DC is supplied from the SLBC unit.

- (2) Transmitter load resistance selector switches (PULSE INPUT).

When a two-wire pulse transmitter is used with SLBC internal power supply distributor (see (1) above), the load resistance (200Ω, 510Ω or 1 kΩ) is selected by these switches. One of these switches turns the input filter On or Off.

- (3) Control action selector switch (ACTION).

This switch is used to select the control action:
DIR (Direct action):

If the process variable value is higher than the set value, the output increases.

PV (process variable value) > SV (set value)
→ MV (control output) increases.

RVS (Reverse action):

If the process variable value is higher than the set value, the output decreases.

PV (process variable value) > SV (set value)
→ MV (control output) decreases.

- (4) Keyboard enable/inhibit switch (ENABLE/INHIBIT).

This switch is used to enable or inhibit data setting by the front panel switches.

ENABLE: Data setting is allowed.

INHIBIT: Data setting is not allowed.

- (5) Data/decimal point selector switch (D.P./DATA).

This switch is used for setting the decimal point position of the set data. With this switch set to DP, the decimal point can be set using the front panel switches (SHIFT, SET).

- (6) Main data/auxiliary data selector switch (FRONT P./SIDE P.)

This switch designates the data to be displayed on the front panel data display as either main data or auxiliary data.

FRONT P.: Main data is displayed

SIDE P.: Auxiliary data is displayed

(7) Data label.

The data label lists auxiliary data such as K factors and other computational constants, control constants and function-specifying data.

Write data values in the data field.

Table 5-1-1 shows the data label, and Table 5-1-2 shows details of the auxiliary data function specifica-

tion items (item Nos. 21, 22 and 23).

For further details of the data label, refer to TI 1B4E1-01E "YewSeries BCS (Style E) Batch-Blending Control System Functions and Data Setting and TI 1B4A3-01E "YewSeries BCS Batch-Blending Control System".

Table 5-1-1. SLBC Data Label.

SLBC * E Batch Controller		TAG No.	
01	Alarm (ALM) code		
02	Batch flow totalizer value (uncompensated)		
03	Batch flow totalizer value (compensated)		
04	Cumulative totalizer value (uncompensated)		
05	Cumulative totalizer value (compensated)		
06	Initial totalized flow limit		
07	Prebatch set value		
08	Predicted leakage value		
09	Leakage detection set value		
10	Initial flow setting		
11	Flow low limit setting		
12	Flow rise time		
13	Flow fall time		S
14	Integral time		
15	Proportional band		%
16	Measured temperature/compensation coefficient input		
17	Measured pulse input filter		
18	Added/subtracted pulse input filter		S
19			
20			
21	Function specification (1)		
22	Function specification (2)		
23	Function specification (3)		
24			
25	Flow process variable span		
26	Added/subtracted flow span		
27	K factor for flow process variable		
28	K factor for added/subtracted flow		
29	K factor for repeater pulse		
30	Totalizer scale factor		
31	PI control input/analog display/flow signal repeater span		
32	Compensation reference temperature		
33	Manual set temperature/Manual compensation coefficient		
34	Maximum value of measured temperature/Maximum value of compensation coefficient		
35	Minimum value of measured temperature/Minimum value of compensation coefficient		
36	Compensation factor		
37	Flow transmitter error compensation coefficient α		
38	First order compensation coefficient, ρ , density or specific gravity		
39	Second order compensation coefficient γ		
40			

* with added/subtracted flow signal

Table 5-1-2. Function-Specifying Data.

Note: Fill in the blanks of 21. Function specification (1), 22. Function Specification (2) and 23. Function specification (3) according to the following items:

<p>Function specification (1) A B C D E F</p> <p>A. Operation mode/backup mode for supervisory system 0: Batch control/Manual backup 1: Batch control/Automatic backup 2: Constant flow control/Manual backup 3: Constant flow control/Automatic backup 4: Batch master/Manual backup 5: Batch master/Automatic backup 6: External setting/Manual backup 7: External setting/Automatic backup</p> <p>B. Repeater pulse width 0: Duty cycle 50% for connection to YS-BCS Instrument 1: 0.5ms 4: 33ms 2: 1ms 5: 50ms 3: 20ms 6: 100ms</p> <p>C. Communications write and keyboard setting enable/inhibit selector 0: Enable/whole data 1: Inhibit/whole data 2: Enable/main data SUM aux. data No. 2 to 6, after No. 21 3: Inhibit/main data SUM aux. data No. 2 to 6, after No. 21</p> <p>D. Instantaneous power failure restoring mode 0: COLD 1: HOT</p> <p>E. External stop input and master pacing enable/inhibit</p> <table border="1"> <thead> <tr> <th>External stop input</th> <th>Master pacing input</th> </tr> </thead> <tbody> <tr><td>0: Inhibit</td><td>Inhibit</td></tr> <tr><td>1: Enable</td><td>Inhibit</td></tr> <tr><td>2: Inhibit</td><td>Enable</td></tr> <tr><td>4: Enable</td><td>Enable</td></tr> </tbody> </table>	External stop input	Master pacing input	0: Inhibit	Inhibit	1: Enable	Inhibit	2: Inhibit	Enable	4: Enable	Enable	<p>F. START/RESET/STOP switch 0: Inhibit 1: Enabled</p> <p>Function specification (2) G H I J K L</p> <p>G. Time unit of flow 0: */h 1: */min 2: */day</p> <p>H. Flow signal/simulation specification 0: Pulse flow signal 1: Analog flow signal 2: Simulation MV inhibit, D/O inhibit 3: Simulation MV inhibit, D/O enable 4: Simulation MV enable, D/O inhibit 5: Simulation MV enable, D/O enable</p> <p>I. Added/subtracted flow signal 0: Not provided 1: Provided, pulse, addition 2: Provided, pulse, subtraction 3: Provided, analog, addition 4: Provided, analog, subtraction</p> <p>J. Analog input signal processing</p> <table border="1"> <thead> <tr> <th>Low cutoff</th> <th>Square root extraction</th> </tr> </thead> <tbody> <tr><td>0: 1% or less</td><td>Not provided</td></tr> <tr><td>1: 0% or less</td><td>Not provided</td></tr> <tr><td>2: 1% or less</td><td>Provided</td></tr> <tr><td>3: 0% or less</td><td>Provided</td></tr> </tbody> </table> <p>K. Resetting of stored totalizer and repeater pulse values: 0: All values reset.</p>	Low cutoff	Square root extraction	0: 1% or less	Not provided	1: 0% or less	Not provided	2: 1% or less	Provided	3: 0% or less	Provided	<p>1: Repeater & non-displayed totalizer digits preserved. 2: Like 1, but least-significant totalizer display digit also preserved. 3: Like 1, but two least-significant totalizer display digits also preserved.</p> <p>L. Compensation</p> <table border="1"> <thead> <tr> <th>Compensation provided for:</th> <th>Process variable input</th> <th>Added/subtracted input</th> </tr> </thead> <tbody> <tr><td>0:</td><td>Not provided</td><td>Not provided</td></tr> <tr><td>1:</td><td>Provided</td><td>Not provided</td></tr> <tr><td>2:</td><td>Not provided</td><td>Provided</td></tr> <tr><td>3:</td><td>Provided</td><td>Provided</td></tr> </tbody> </table> <p>Function specification (3) M N O - Q -</p> <p>M. Compensation computation 0: ASTM method 1: General quadratic formula 2: General computation</p> <p>N. Temperature/compensation coefficient data 0: Process variable 1: Manual set value</p> <p>O. Temperature unit 0: °C 1: °F</p> <p>Q. Selection of ASTM compensation equation (Effective when M=0 in function specification (3)) 0: Old ASTM (ASTM-52) 1: New ASTM (ASTM-80, ISO 91/1) Crude oil 2: New ASTM (ASTM-80, ISO 91/1) Fuel oil 3: New ASTM (API, ISO) Lubricating Oil</p>	Compensation provided for:	Process variable input	Added/subtracted input	0:	Not provided	Not provided	1:	Provided	Not provided	2:	Not provided	Provided	3:	Provided	Provided
External stop input	Master pacing input																																				
0: Inhibit	Inhibit																																				
1: Enable	Inhibit																																				
2: Inhibit	Enable																																				
4: Enable	Enable																																				
Low cutoff	Square root extraction																																				
0: 1% or less	Not provided																																				
1: 0% or less	Not provided																																				
2: 1% or less	Provided																																				
3: 0% or less	Provided																																				
Compensation provided for:	Process variable input	Added/subtracted input																																			
0:	Not provided	Not provided																																			
1:	Provided	Not provided																																			
2:	Not provided	Provided																																			
3:	Provided	Provided																																			

5-2. Preparation of Data Label.

Before using the SLBC+E controller, the required values of auxiliary data items – such as function specifying data, K factors and other computational and control constants – must be decided and input, and these values should also be written on the data label (see note).

When preparing the data label, refer to TI 1B4E1-01E "YewSeries BCS (Style E) Batch-Blending Control System Functions and Data Setting" and TI 1B4A3-01E "YewSeries BCS Batch-Blending Control System".

NOTE

If option/DL is specified at order time, the factory will write data values on the data label before shipping the controller.

5-3. Preparation for Operation.

Perform preparation with the controller installed in the panel, or removed and placed on a work table. (Suppose that the instrument module is in the housing).

Removing the instrument module from the housing:

- ① Push up the stopper, located below the front panel of the instrument module, to remove it. When it is drawn out halfway, the instrument module is stopped by an intermediate stopper. (Figure 5-3-1).

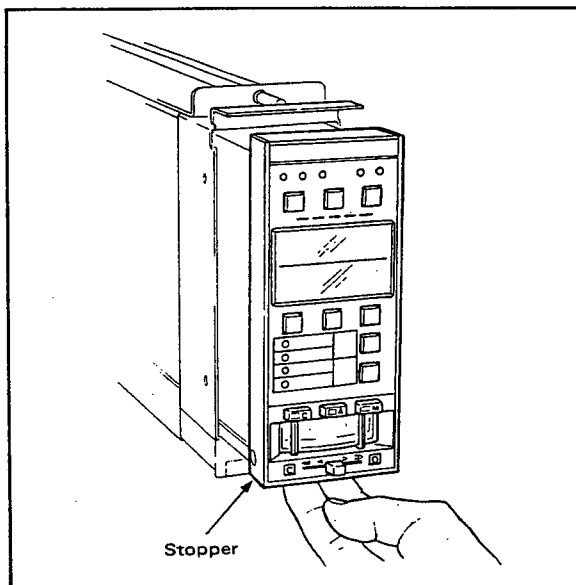

Figure 5-3-1. Removing Instrument Module.

- ② To remove the instrument module from the housing, push down on the intermediate stopper while pulling the instrument out of the housing as shown in Figure 5-3-2.

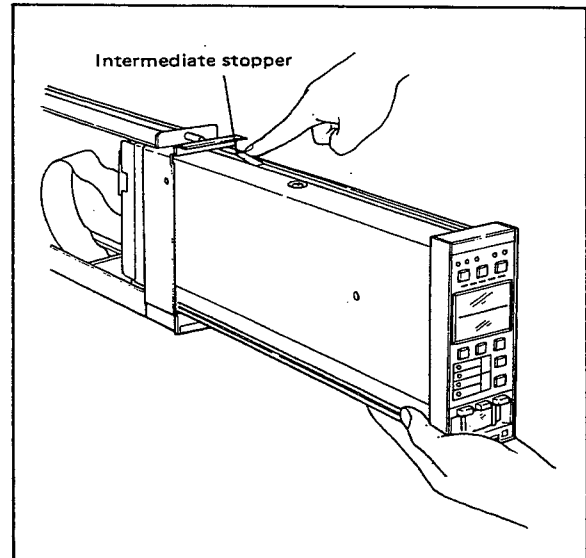

Figure 5-3-2. Removing Instrument Module.

- ③ Detach the connector from the instrument module. The instrument module is now separated from the housing. (Figure 5-3-3).

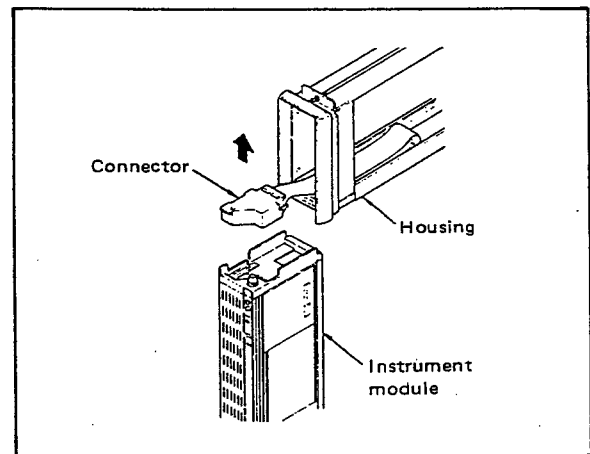

Figure 5-3-3. Detaching the Connector.

5-3-1. Check Special Parts are Installed.

Check to see that the fuse and data memory backup battery are installed. If not, refer to Chapter 6 "Maintenance" for installation procedure.

5-3-2. Setting Side Panel Switches.

- (1) Transmitter power supply selector switch (TRANSMITTER PWR SPLY).

For pulse type process variable input signals (two-wire distributor type or three-wire distributor type, see Table 3-1-1, note *1) a distributor in the SLBC+E unit supplies 12 or 24 V DC.

The switch setting is irrelevant for two-wire voltage level or contact pulse inputs (left side of Table 3-1-1, note *1).

- (2) Transmitter load resistance selector switch (PULSE INPUT).
 - When using a two-wire pulse transmitter with the distributor in the SLBC*E unit, the switch corresponding to the desired load resistance should be turned ON. When using any other type of transmitter, be sure to turn all of the resistance switches OFF.
 - If input filtering is needed, turn the FILTER switch ON. Further, when the repeater pulse from YEW-SERIES BCS instrument is applied as the input signal, be sure to turn the input FILTER switch OFF.

NOTE

Select an appropriate time-constant from 0 to 9999 seconds and set it into the auxiliary data items 17 and 18 "Pulse Input Filters", when the displayed value of instantaneous flow (or analog flow repeater signal) wavers owing to the irregularity of input pulse signal.

As for setting operation to instrument, refer to Chapter 5-3-4 (Setting Auxiliary Data).

- (3) Control action selector switch (ACTION).
Set to the desired control action position.
- (4) Data setting enable/inhibit switch (ENABLE/INHIBIT)
Set this switch to INHIBIT during normal operation.
- (5) Data/decimal point selector switch (D.P./DATA).
Set this switch to DATA during normal operation and set this switch to D.P. when decimal point position is set.
- (6) Main data/auxiliary data selector switch (FRONT P./SIDE P.)
Set this switch to FRONT P. (main data) during normal operation and set this switch to SIDE P. when auxiliary data is set.

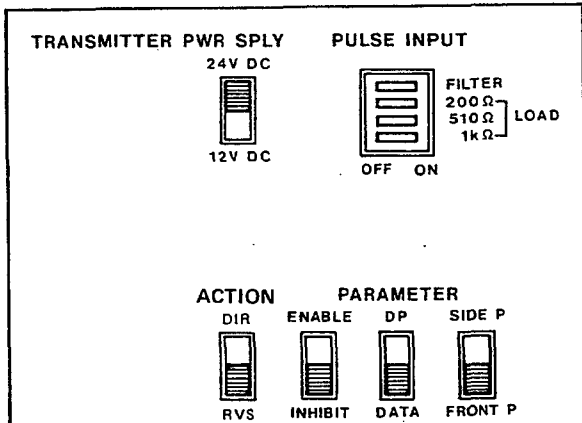

Figure 5-3-4. Side Panel Switches.

5-3-3. Setting Main Data.

The following main data must be set before commencing operation.

Batch set value (BATCH)

Flow high limit set value (FLOW LIMIT)

- (1) Setting the data.

Turn on the power, set the main data/auxiliary data selector switch on the side panel to FRONT P. (main data) position, set the data/decimal point selector switch to DATA, then select the data item to be set and display it on the lower section of the display using the data display selector switches ▲▼. Next, perform the following operations.

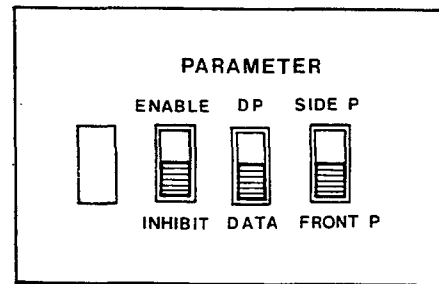

Figure 5-3-5.

[Example of display and setting (Setting batch set value)]

Switch operation	Display (lower)	Description
	□□□□□□	The initial value of the batch set value or an already set value is indicated.
SHIFT ►	(Note) □□□□□□	The most significant digit that may be set flashes.
INCR ▲	5□□□□□	Set the desired data. If setting is not needed, go to the next step.
SHIFT ►	5□□□□□	The next most significant digit flashes.
INCR ▲	52□□□□	Set the desired data. If setting is not needed, go to the next step.
INCR ▲	520000	Repeat the above setting operation to the least significant digit.
SET	520000	The whole data thus set flashes.
SET	520000	Data setting is completed.

Note: The shaded portion ■ indicates flashing of data display.

(2) Setting the decimal point.

The batch set value decimal point position is automatically set to coincide with the decimal point position of the cumulatively totalized value of auxiliary data item 04. Similarly, the decimal point position of the flow high limit set value is automatically set to coincide with the process variable flow span — auxiliary data item 25.

Accordingly, the decimal point position need not be set when setting the main data.

5-3-4. Setting Auxiliary Data.

As described below, the auxiliary data values must be set to correspond with the data on the data label prepared in section 5-2:

NOTE

If this controller has been ordered with data label (option /DL), the data has already been set at the factory according to the data label prepared by YOKOGAWA. Before starting operation, be sure to check that each data item has been set correctly (to correspond with the label). If any error is found, correct the data setting as explained below.

NOTE

Auxiliary data should be set in the sequence items 21 thru 39, items 04 thru 18.

(1) Setting the decimal point.

Set the main data/auxiliary data selector switch on the side panel to SIDE P. (auxiliary data) position, set the data/decimal point selector switch to the DP position, then set the data setting enable/inhibit switch to ENABLE. Using the data display selector switches ▲▼, select the data whose decimal point is to be set, and display it on the lower section of the display. Next perform the following operations:

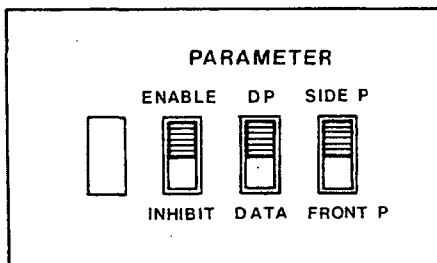

Figure 5-3-6.

[Decimal point position setting example]

Switch operation	Display (lower)	Description
		The initial value is displayed.
SHIFT▶	(Note 1) 	The decimal point of the initial value flashes.
SHIFT▶		When the SHIFT switch is held depressed, the decimal point position changes digit by digit and the decimal point position flashes. When the decimal point reaches the desired position, release the switch.
SET	(Note 2) 	The entire display flashes.
SET		Decimal point setting completed.

Note 1: The * mark indicates a flashing decimal point.
Note 2: The shaded portion indicates flashing digit.

(2) Setting data.

Set the main data/auxiliary data selector switch to SIDE P. (auxiliary data), set the data/decimal point selector switch to DATA, and set the data setting enable/inhibit switch to ENABLE. Then select the data item to be set and display it on the lower display section using the data display selector switches ▲▼. Next set the data. The data is set in the same way as for main data. Refer to the main data setting example of par. 5-3-3.

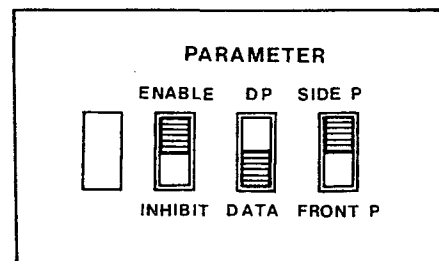

Figure 5-3-7.

After completing data setting, set the data setting enable/inhibit switch to INHIBIT so as to prevent accidental (erroneous) setting.

Unused Auxiliary Data

Auxiliary data that is not being used — according to the function specification — is skipped.

5-3-5. Simulation.

After setting the main and auxiliary data, check the operation of the batch and control functions using the simulation function of this controller. (Refer to TI 1B4A3-01E.)

Set auxiliary data item 22 [function specification (2)] H Process variable flow signal/simulation specification to simulation mode, and check the operation (refer to 5-4-1 "Automatic mode (Batch operation)" and Table 5-3-1 below).

In simulation mode, contact outputs (D/O) and control output (MV) can be inhibited if so specified. (Refer to Table 5-3-1.)

Table 5-3-1. Auxiliary Data Simulation Specifying Item.

22. Function specification (2)	
G H I J K L	
H	Process variable flow signal/simulation specification
	0: Pulse
	1: Analog
	2: Simulation, MV inhibit, D/O inhibit
	3: Simulation, MV inhibit, D/O enable
	4: Simulation, MV enable, D/O inhibit
	5: Simulation, MV enable, D/O enable

5-3-6. Other Preparations.

(1) Attach coefficient/units label.

Choose suitable coefficient and engineering units labels from those supplied with the controller, and stick them in the appropriate place on the front panel. (See Figure 5-3-8.)

If a suitable label is missing, use a blank label and write the necessary coefficient or units on it.

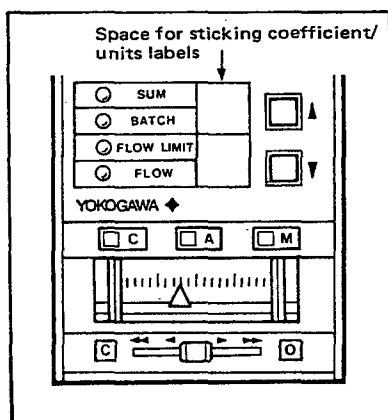

Figure 5-3-8.

(2) Mounting control valve action labels (Figure 5-3-9).

Match the label location with the action (normal or reverse action) of the control valve.

The labels can be removed using tweezers or finger nails.

- C: CLOSE (Control valve closing direction).
- O: OPEN (Control valve opening direction).

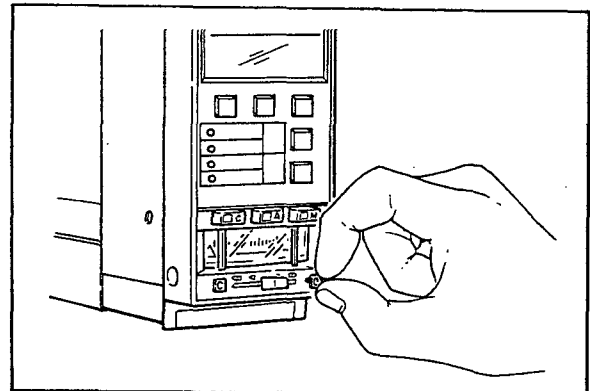

Figure 5-3-9. Mounting Control Valve Action Labels.

5-4. Operation and Handling.

5-4-1. Batch Loading (Batch Operation).

After setting main data and auxiliary data, start up the controller as described below. If the integral time and proportional band have already been set (that is, for daily start up), steps ② and ⑥ are unnecessary.

Figure 5-4-2 shows the batch sequence operation, flow characteristics, status input/output operation and lamp display.

Note that the operations required to start pumps and other devices are not described in this manual.

- ① Turn on the power to the instrument.
- ② Set the control mode to M, and set the integral time to 9999 s. Set the proportional band to a sufficiently large value.
- ③ Set the control mode to A, or - to enable setting and control from a supervisory system - set the control mode to C.
- ④ Turn ON the reset signal (front panel RESET switch or status input).

The batch totalizer value will be reset. If the stop status input is ON, the instrument is ready to start. Note that the instrument cannot be restarted immediately after normal batch end without first resetting it. An interlock function of this instrument disables the reset signal during a batch sequence.

- ⑤ Turn the start signal (front panel START switch or status input) ON.
This controller operates automatically according to the batch sequence, and stops automatically when the totaled flow reaches the batch loader set value. Figure 5-4-2 shows the change in the flow during the batch cycle.
- ⑥ Set the integral time and proportional band according to the procedure described in 5-4-3 "Automatic control".
- ⑦ To stop operation in the middle of a batch cycle, press the front panel stop switch; or turn the stop status input OFF. The flow ramps down to the flow low limit in a preset time, and then goes to zero.
- ⑧ To resume operation after stopping in the middle of a batch cycle, turn ON the start signal without resetting. The remaining quantity is then loaded, so that the totaled flow coincides with the batch loader set value. To restart the batch cycle, begin with step (4) above.

- ⑨ If the master pacing status input is turned OFF during operation at the flow high limit, the flow ramps down to the flow low limit in a preset time. If the master pacing status input is then turned ON, the flow ramps up to the flow high limit in a preset time.

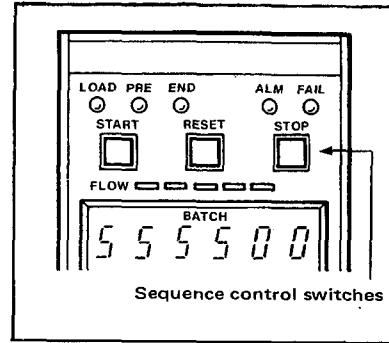

Figure 5-4-1.

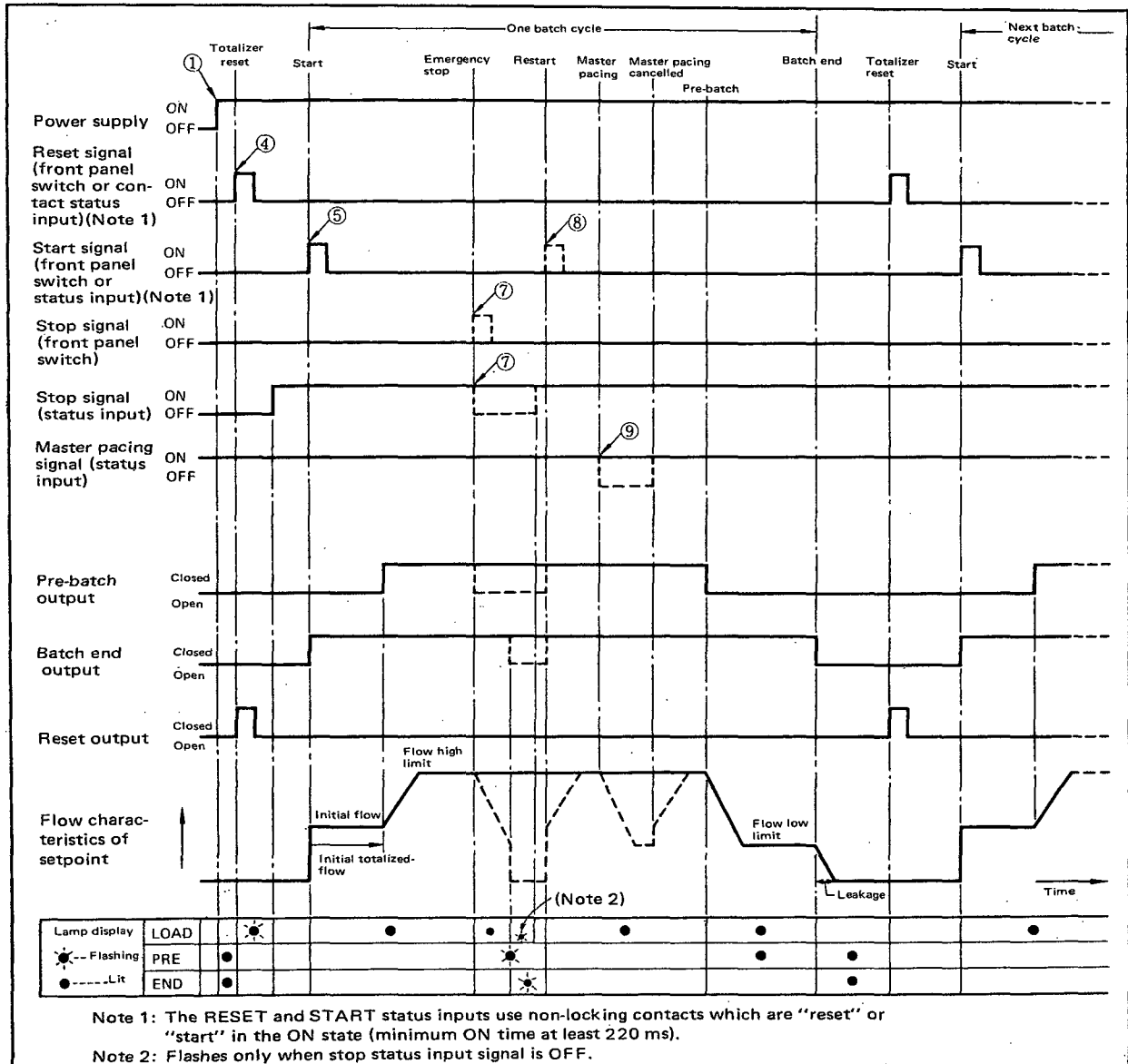

Figure 5-4-2. Batch Sequence and Flow Characteristics.

5-4-2. Fixed Flow PI Controller.

After setting main data and auxiliary data, start up the controller as described below. If the integral time and proportional band have already been set (that is, for daily start up), steps ② and ⑥ are unnecessary.

Figure 5-4-3 shows the sequence operation, flow characteristics, status input/output operation and lamp display.

Note that the operations required to start pumps and other devices are not described in this manual.

- ① Turn on the power to the instrument.
- ② Set the control mode to **M**, and set the integral time to 9999 s. Set the proportional band to a sufficiently large value.
- ③ Set the control mode to **A**, or **-** to enable setting and control from a supervisory system — set the control mode to **C**.
- ④ Turn ON the reset signal (front panel RESET switch or status input).
The batch totalizer value will be reset. If the

stop status input is ON, the instrument is ready to start. If resetting is unnecessary, skip step ④ and go to step ⑤.

- ⑤ Turn the start signal (front panel START switch or status input) ON.

This controller operates automatically according to the sequence. Figure 5-4-3 shows the change in the flow during the batch cycle.

- ⑥ Set the integral time and proportional band according to the procedure described in 5-4-3 "Automatic control".
- ⑦ To stop operation, press the front panel stop switch, or turn the stop status input OFF. The flow ramps down to the flow low limit in a preset time, and then goes to zero.
- ⑧ If the master pacing status input is turned OFF during operation at the flow high limit, the flow ramps down to the flow low limit in a preset time. If the master pacing status input is then turned ON, the flow ramps up to the flow high limit in a preset time.

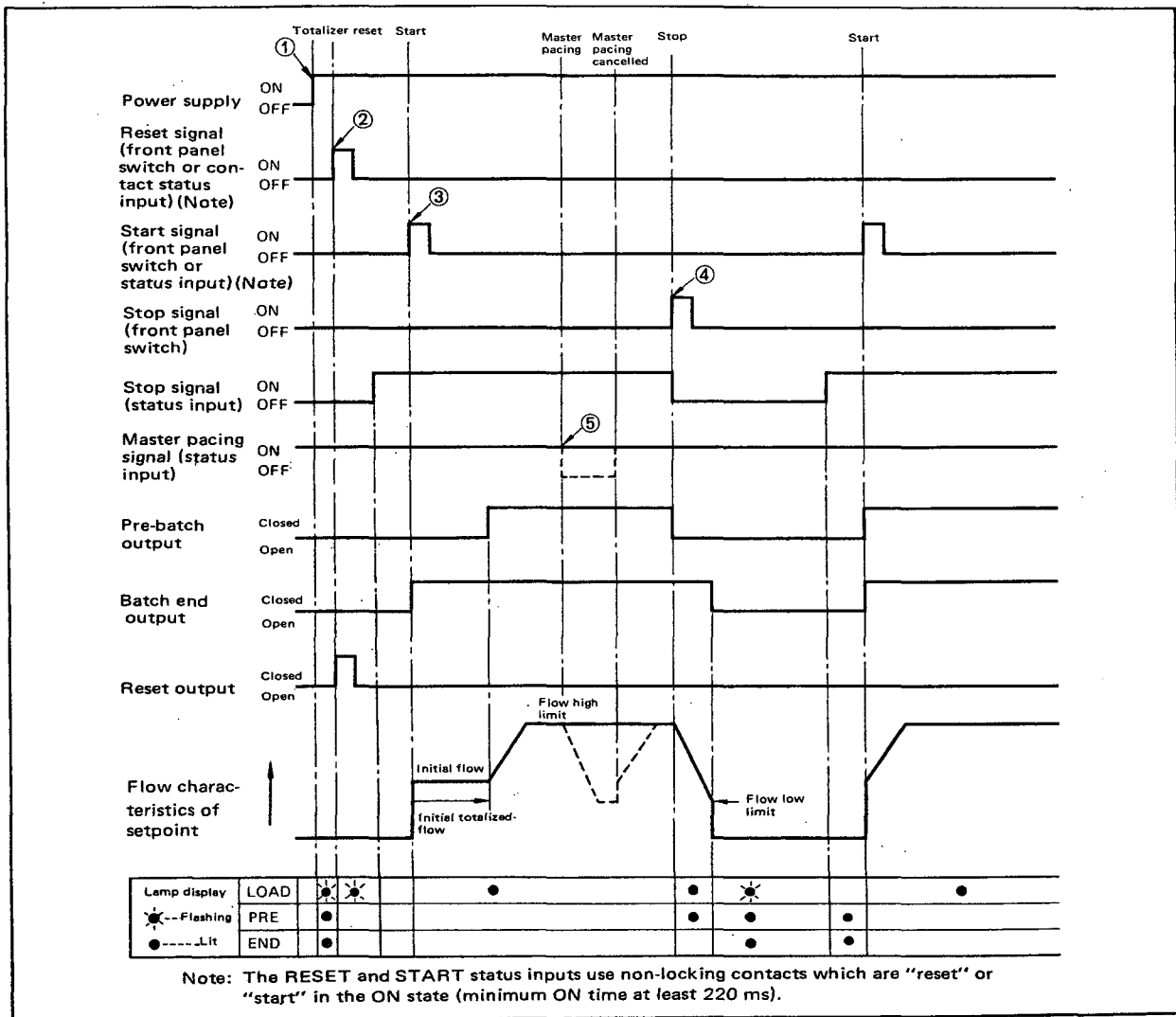

Figure 5-4-3. Sequence and Flow Characteristics of Fixed Flow PI Controller.

5-4-3. Automatic Control.

The procedure for setting controller integral time and proportional band is explained below. In general, if a small change in the controller output causes a large fluctuation in the process variable value, the width of the proportional band must be increased (the gain must be reduced) to assure stability. In the converse case, the proportional band must be narrowed.

For a process which responds quickly to a change in the controller output, the integral time constant must be small. For a process having a long recovery time, the integral time constant must be large.

Set the integral time and proportional band as follows:

- (1) Set the control mode to **M**, and the integral time to 9999 s. Set the proportional band to a sufficiently large value, and then set the control mode to **A**.
- (2) To obtain the optimum value for the proportional band, perform the following operations: Decrease the value of proportional band from its initial large value in steps (for example, from 100% to 50% to 20%). Take a sufficiently long time for each step, so that the state of control can be observed fully. Continue this operation until the control loop begins cycling. (Cycling means periodic (cyclic) oscillation of the process variable pointer around the set point, and this phenomenon is caused by setting the proportional band narrower (setting the gain higher) than the optimum value for the process.) If cycling occurs, increase the width of the proportional band until the meter indication stabilizes.

- (3) Decrease the integral time in steps. Up to a point, decreasing the integral time improves the speed of response of the controller, but if the integral time is shortened too far, cycling is caused due to dead time in the process. In such a case, increase the integral time gradually until the cycling disappears.

5-4-4. Transfer between Control Modes.

The control mode of the controller can be changed freely by depressing the C/A/M pushbutton switches. (Figure 5-4-4). (Note, however, that direct changeover from **M** to **C** modes is not allowed.) Transfer between modes is bumpless, and no balancing operation is required.

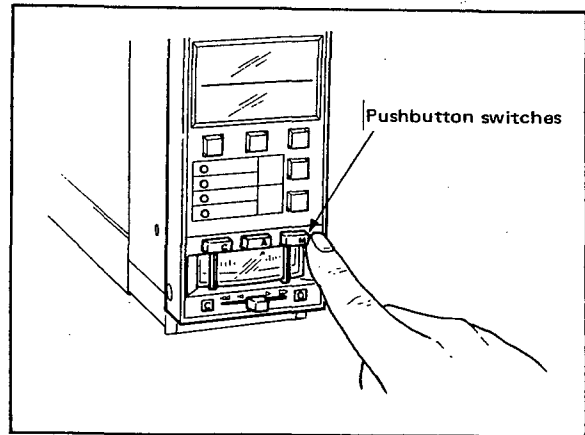

Figure 5-4-4. Transfer between Control Modes.

5-4-5. Manual Mode.

- (1) Of the C/A/M mode selector switches, select **M**. (The lamp inside the pushbutton lights.) (Figure 5-4-4).
- (2) Move the manual control lever to left (or right) to adjust the output signal. (Figure 5-4-5).

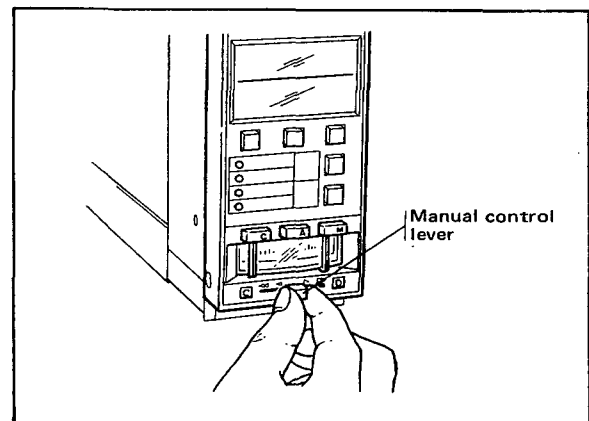

Figure 5-4-5. Manual Output Control.

Manual operation is possible anywhere between batch start and batch end. If batch end is reached during manual operation, manual operation is automatically stopped, and the output returns instantly to zero.

5-4-6. Resetting Cumulative Totalizer Value.

The cumulative totalizer values contained in auxiliary data items 04 and 05 are not reset by the reset signal. If resetting is needed, set this auxiliary data to zero using the data setting switches. For the setting procedure, refer to 5-3-4 "Setting of auxiliary data".

5-5. Action to be Taken when FAIL or ALM Lamps Light.

Any faults in the controller or in the signal connections are indicated by the FAIL or ALM lamps lighting. If either of these lamps lights (or begins flashing), please take appropriate action (as described below) without delay.

5-5-1. Action to be Taken when FAIL Lamp Lights.

When the FAIL lamp lights and the FAIL contact output opens, this indicates that a serious fault has occurred inside the instrument.

- (1) Monitor the current output signal, and set it to a safe level using the manual control lever. (In FAIL status, the current output can be directly controlled by the manual control lever. The value of other analog and digital output signals depends on the type of fault.)
- (2) Set the main data/auxiliary data selector switch to the auxiliary data position to indicate the alarm (ALM) contents of auxiliary data item 01 on the data display, and check the cause of the fault. (See Figure 5-5-4.) Take appropriate action to correct the fault.
- (3) If the data display does not function normally, it can be presumed that the microprocessor is not operating.

5-5-2. Action to be Taken when ALM Lamp Lights.

The ALM lamp lights if the high or low limit alarms of the controller operate, or when input-output signals are disconnected.

Display the alarm (ALM) contents of auxiliary data item 01 on the data display, and examine the cause of the fault. (See 5-5-4.) Take appropriate action corresponding to the cause of the fault.

5-5-3. Action to be Taken when ALM Lamp Flashes.

The ALM lamp begins flashing if the voltage of the data memory backup battery is low. Replace the battery with a new one. (See section 6-4 for replacement procedure.)

NOTE

- (1) If the ALM lamp begins to flash during normal operation, replace the battery within one month.
- (2) The flashing of the ALM lamp has precedence over its continuous lighting. Thus, other alarms cannot be displayed while the lamp is flashing.

5-5-4. Alarm (ALM) Codes, their Meanings and Control Actions when Abnormal.

The alarm codes and their meaning are listed below.

Code	Lamp	Meaning	Control action when abnormal
0000	—	Normal	—
—	FAIL	Fault in CPU	FAIL contact opens
0001	FAIL	Fault in A/D converter	
0002	FAIL	Fault in D/A converter.	
0004	ALM	Computation range overflow	Computation with limit value
0008	ALM	Temperature input/compensation input signal out of range	Computation with manual set value/manual compensation coefficient.
0010 (note)	ALM	Error in compensation computation	• Computation is performed with limit value. • Control is continued.
0020	ALM (flashing)	Data memory backup battery not installed, or low battery voltage	Normal operation unless power failure occurs
0040	ALM	Control output open circuit	Control continues
0080	ALM	RAM memory data initialization	Computation with initial value
0100	ALM	Process variable input signal out of range or missing pulse input	Computation with initial value Alarm contact opens when loss of pulse input is detected or leakage is detected
0200	ALM	Added/subtracted input signal out of range	
0400	ALM	Abnormal leakage detection	
0800	ALM	Flow signal out of range (for analog flow display and flow signal repeater span) after addition/subtraction	
2000	ALM	Repeater internal data overflow	
4000	ALM	Data setting out of range	

(Note) In the computation of basic equation (see page 2-3) of volume conversion coefficient, if $|\alpha\gamma\Delta t| > 0.5$, "0010" alarm occurs. At this time, computation is continued with the value limited at 0.5 or -0.5. This processing is executed to prevent the internal data overflow if improper input or set value is applied.



If two or more faults occur simultaneously, the hexadecimal sum of their code numbers is displayed.

[Example]



030C = 0004 + 0008 + 0100 + 0200 (computation range overflow, temperature input/compensation input signal out of range, process variable input signal out of range, added/subtracted input signal out of range)

The diagnostic alarm code display reverts to zero and the ALM lamp turns off when the cause of the fault is removed, except for the following items.

Select these items using the data selector switches   and reset them using the **SET** key.

The items to be reset using the **SET** pushbutton switch

- RAM memory data initialization
- Abnormal leakage detection
- Repeater internal data overflow

6. MAINTENANCE.

This chapter explains the indicator adjustment and parts replacement procedures.

6-1. Adjusting Zero Point of Control Output Indicator.

Pull the instrument module about 80 mm out of the housing. The zero point adjustment is located under the module, approximately 60 mm from the front panel.

Adjust the zero using a standard screwdriver. (See Figure 6-1-1).

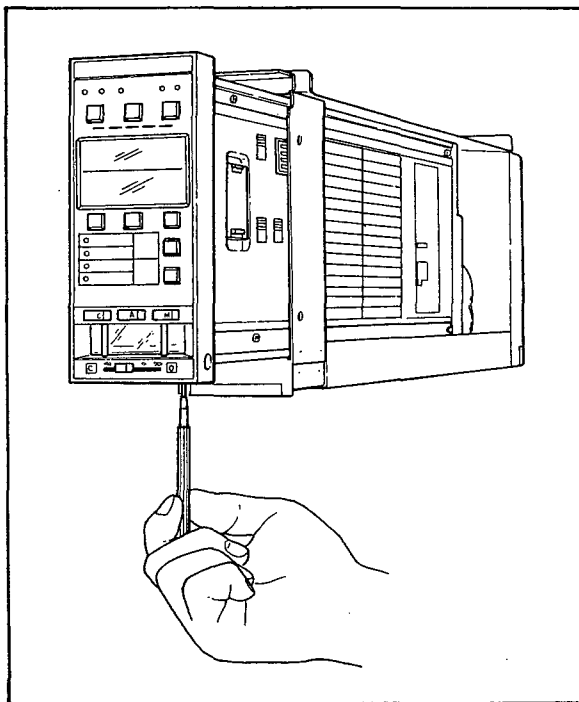

Figure 6-1-1. Adjusting Zero Point of Control Output Indicator.

6-2. Replacing Nameplate (Tag Label).

Draw out the instrument module a little from its housing, and open the lid located on the top of the front panel. Remove the nameplate, and install a new one. (Figure 6-2-1).

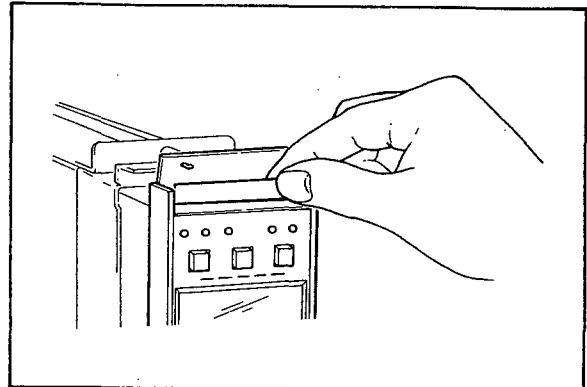

Figure 6-2-1. Replacing Nameplate.

6-3. Replacing Fuse.

If it seems that the fuse may be faulty, check the inside of the fuse holder for contamination or poor contact with fuse.

Recommended replacement interval: About 3 years.

- (1) To remove the fuse, unscrew the fuseholder cap (turn it in the direction of the arrow marked on the cap — counterclockwise); the cap and fuse may then be removed.
- (2) Install a new fuse of the correct rating. Tighten the cap firmly.

Note: Use the dedicated fuse (S9510VK). Do not use a fuse for other products.

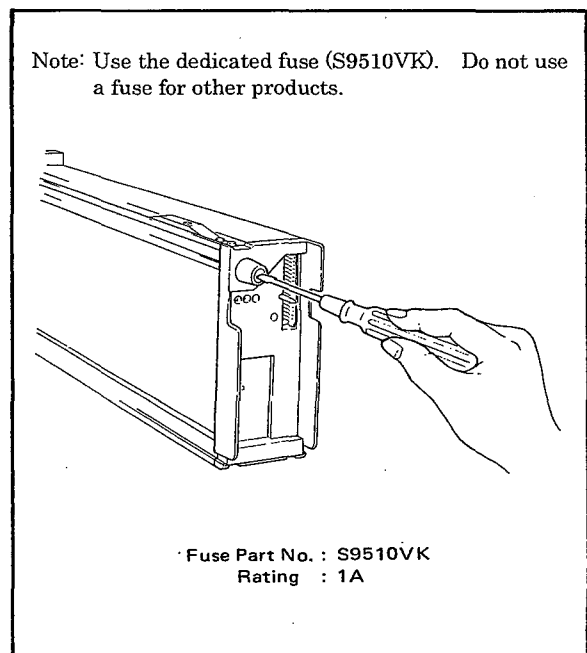

Figure 6-3-1. Replacing Fuse.

6-4. Replacing Data Memory Backup Battery.

If the ALM lamp on the front panel of the instrument begins flashing, please replace the battery without delay.

Recommended replacement intervals:

About 5 years (charging, at ambient temperatures below 45°C)

About 1 year (shelf-life, at ambient temperatures below 45°C)

NOTE

Leave power applied to the instrument while replacing the battery. If the battery is removed while the power is off, data (parameter) settings may be lost.

- (1) Draw out the controller module a little from the housing, and remove the battery cover and battery. (See Figures 6-4-1 and 6-4-2.)
- (2) Install a new battery, and fit the battery cover securely.
- (3) Make sure that the ALM lamp on the front panel has stopped flashing.

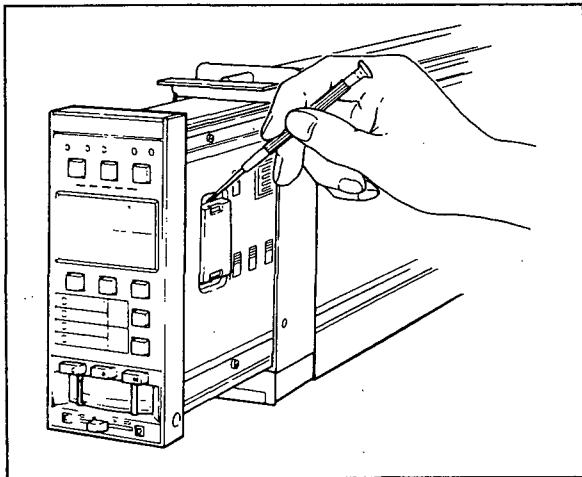

Figure 6-4-1. Removing Battery Cover.

[Precautions for storage and handling of data memory backup batteries]

(1) Storage conditions

Ambient temperature: -10 to 60°.

Ambient humidity: 5 to 95% RH (non-condensing).

Location free from corrosive gases.

(2) Replace the complete battery assembly (battery in plastic plug-in package).

(3) When measuring the battery voltage, be sure to use a high impedance voltmeter. Do not attempt to measure the voltage using a circuit tester or the like.

(4) Cautions in handling batteries

- Do not charge the batteries.
- Do not heat or put into a fire.
- Do not short the positive and negative poles together.
- Do not apply shock, do not attempt to disassemble.

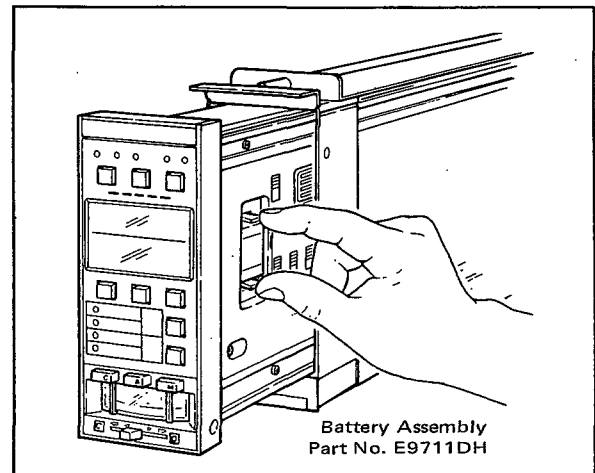

Figure 6-4-2. Removing Battery.

YEW SERIES BCS SLBC * E BATCH CONTROLLER DATASHEET

Spec. No.			
YOKOGAWA Order No.	SEC.	Loop	Item
Instrument No.			
Model and Suffix Codes SLBC-			

Customer: _____

Equipment: _____

SLBC * E Batch Controller		TAG No.	
01	Alarm (ALM) code		
02	Batch flow totalizer value (uncompensated)		
03	Batch flow totalizer value (compensated)		
04	Cumulative totalizer value (uncompensated) *		
05	Cumulative totalizer value (compensated) *		
06	Initial totalized flow limit		
07	Prebatch set value		
08	Predicted leakage value		
09	Leakage detection set value		
10	Initial flow setting		
11	Flow low limit setting		
12	Flow rise time		
13	Flow fall time		S
14	Integral time		
15	Proportional band		%
16	Measured temperature/compensation coefficient input		
17	Measured pulse input filter		
18	Added/subtracted pulse input filter		S
19			
20			

21	Function specification (1)			31	PI control input/analog display/flow signal repeater span *		
22	Function specification (2)			32	Compensation reference temperature		
23	Function specification (3)			33	Manual set temperature/Manual compensation coefficient		
24				34	Maximum value of measured temperature/Maximum value of compensation coefficient		
25	Flow process variable span			35	Minimum value of measured temperature/Minimum value of compensation coefficient		
26	Added/subtracted flow span			36	Compensation factor		
27	K factor for flow process variable			37	Flow transmitter error compensation coefficient α		
28	K factor for added/subtracted flow			38	First order compensation coefficient ρ / density or specific gravity ρ_s		
29	K factor for repeater pulse			39	Second order compensation coefficient γ		
30	Totalizer scale factor			40			

* with added/subtracted flow signal

Δ	NO	Revised by	CH.	CH.	K	USER		D		E		K
Δ	/	/	/	/	/	DR.	CH.	DR.	CH.	DR.	CH.	
Δ	/	/	/	/	/							
Δ	/	/	/	/	/							

Customer Maintenance Parts List

Model SLBC (Style E)
Batch Controller

YEW SERIES 80

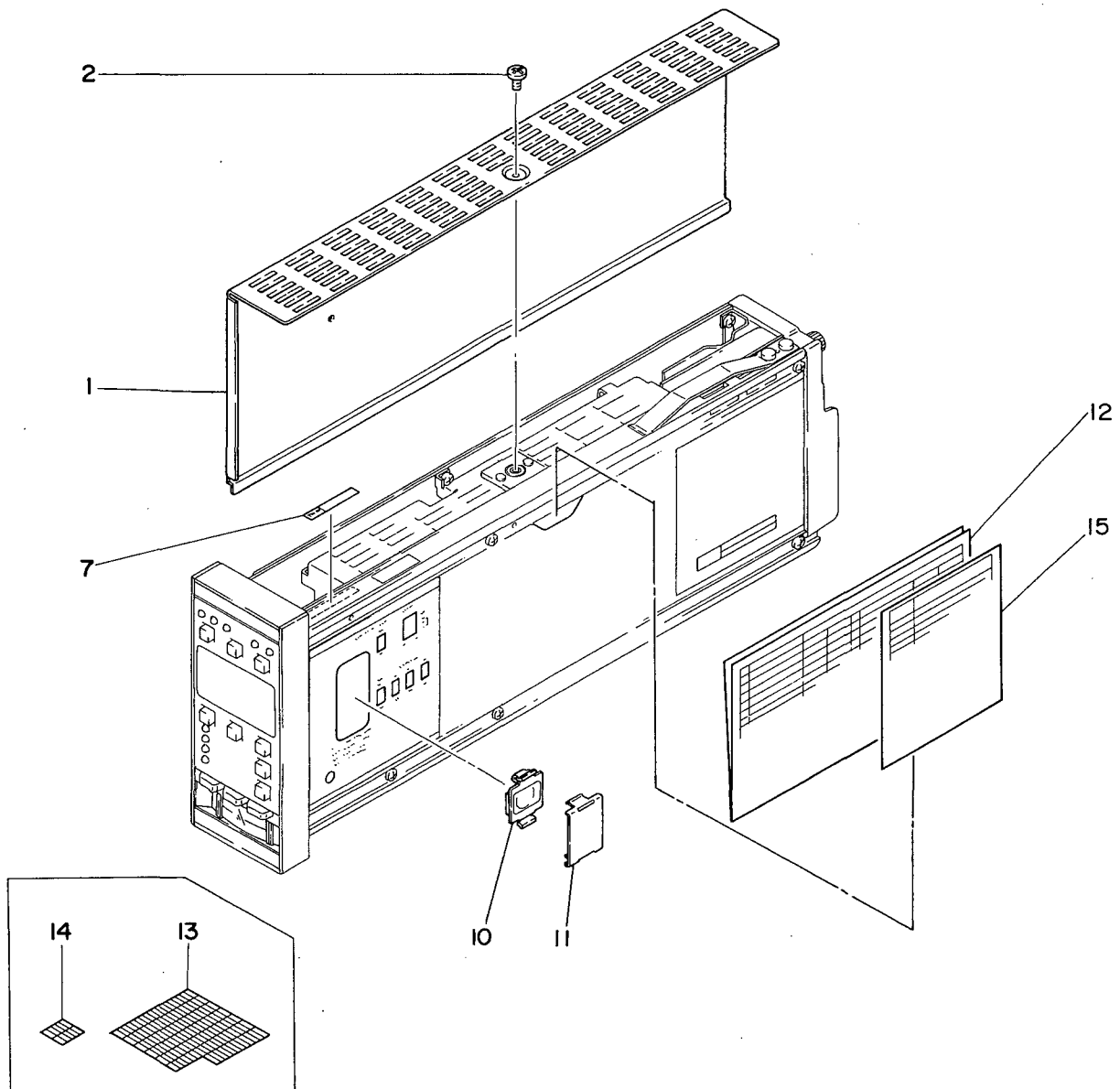

Item	Part No.	Qty	Description
1	E9711TG	1	Cover
2	Y9405LB	1	B.H. Screw, M4 x 5
7	Y9422NP	1	Tag No. Label (blank)
10	E9711DH	1	Battery Assembly
11	E9711GQ	1	Cover
12	E9714RH	1	Data Label
13	E9712DL	1	Label
14	E9712DS	1	Label (blank)
15	E9714RP	1	Alarm Code Sheet

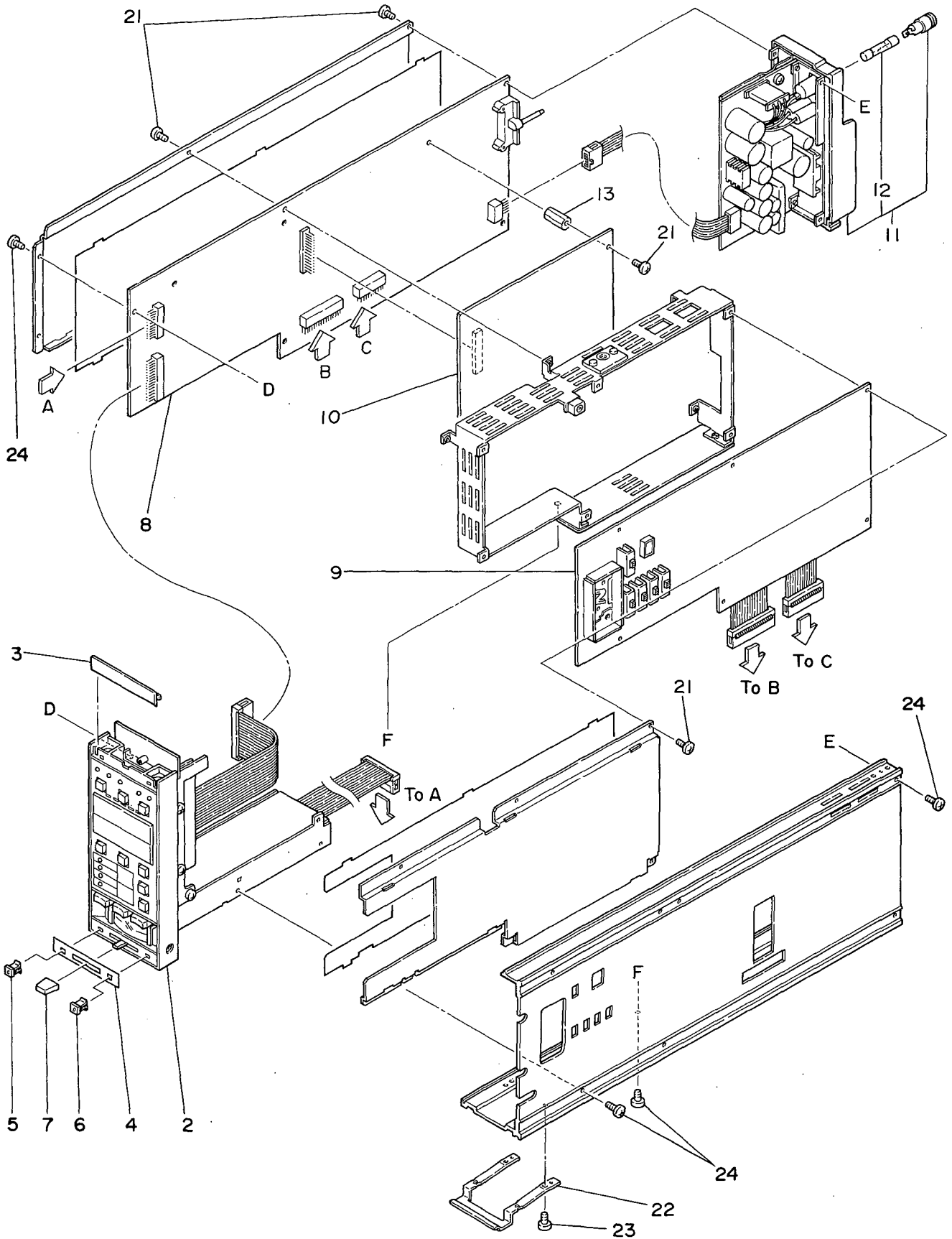

Item	Part No.	Qty	Description
2	—	1	Display Assembly (see page 4)
3	E9711FG	1	Plate (blank)
4	E9711KE	1	Plate
5	E9711KC	1	Tip — "C"
6	E9711KD	1	Tip — "O"
7	E9711KA	1	Knob
—	—	1	Control Assembly (item 8 through 21)
8	E9714TA	1	I/O Card
9	E9714WA	1	CPU Card
10	E9714XA	1	Option Card (for Model SLBC-200*E)
	E9714XB	1	Option Card (for Model SLBC-300*E)
11	E9716YB	1	Power Supply Unit (for 100 V version)
	E9716YS	1	Power Supply Unit (for 220 V version)
12	S9510VK	1	Fuse — "1A"
13	T9008ZB	2	Stud
21	Y9306JB	16	Pan H. Screw, M3 x 6
22	E9711TD	1	Stopper
23	E9711TE	2	Screw
24	Y9306JB	10	Pan H. Screw, M3 x 6

Display Assembly

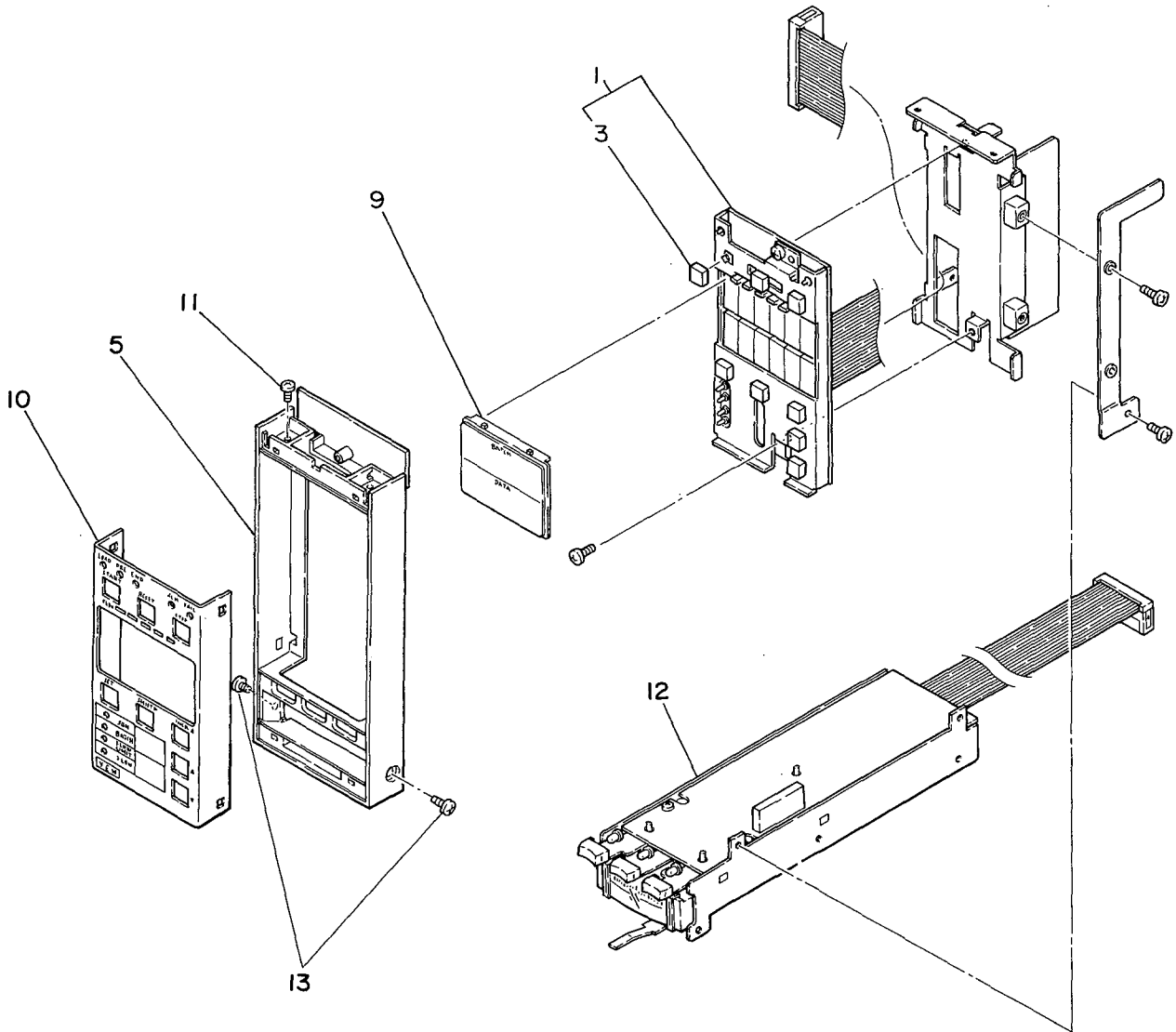

Item	Part No.	Qty	Description
—	E9714GB	1	Display Assembly (item 1 through 11)
1	E9714PE	1	Display Card Assembly
3	E9712CC	8	Key Top
9	E9711GF	1	Cover
10	E9711HC	1	Bracket
11	Y9306JB	2	Pan H. Screw, M3 x 6
12	E9711KX	1	A/M Unit
13	Y9306JB	2	Pan H. Screw, M3 x 6

Instruction Manual

/ HTB Power Supply Terminal Connections for Panel - mounted Instruments (Option)

1. GENERAL.

If you specify the terminal board to which the power source is directly connected (suffix code / HTB), the external wiring to the terminal board is necessary.

2. APPLICABLE INSTRUMENTS.

Model	Description
SRVD	Strip Chart Recorder
SIHM	Indicator (With Housing)
SIHF	Bar Graph Indicator (With Alarms)
SIHK	Indicator (With Alarms)
SLCD	Indicating Controller
SLPC	Programmable Indicating Controller
SLMC	Programmable Indicating Controller with Pulse → Width Output
SMLD	Manual Station
SMST	Auto/Manual Station
SMRT	Ratio Set Station
SCMS	Programmable Computing Station
SBSD	Batch Set Station
SLCC	Blending Controller
SLBC	Batch Controller
STLD	Totalizer

3. NAME OF COMPONENTS AND TERMINAL DESIGNATION OF POWER SUPPLY

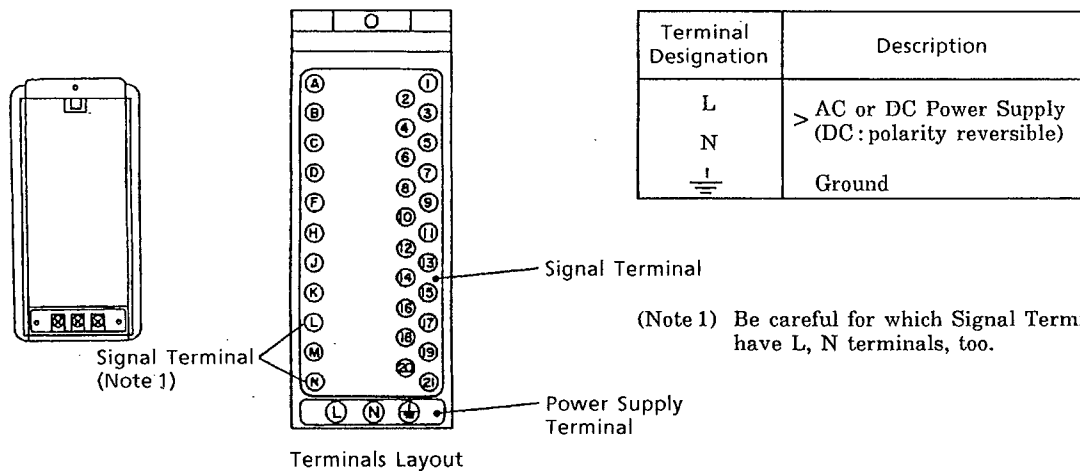

4. POWER SUPPLY AND GROUND WIRING.

(1) All cable ends must be furnished with crimp-on type solderless lugs (for 4mm screw).

(2) Examples of applicable cables.

Cross-sectional area of the cable conductor : 2.0mm².*

Note * : Power supply cables should be determined from the instrument power consumption
- they must have conductors with cross-sectional area of at least 1.25mm².

Applicable cable : 600V vinyl insulated cable (IV), conforming to JIS C3307.

Vinyl sheathed cables for electric appliances (KIV), conforming to JIS C3316.

(3) After completing the power supply and ground wiring, mount the power terminal cover.

YOKOGAWA

Yokogawa Electric Corporation

YOKOGAWA ELECTRIC CORPORATION

Network Solutions Business Div.

2-9-32, Nakacho, Musashino-shi, Tokyo, 180-8750 JAPAN
Phone: +81-422-52-7179 Facsimile: +81-422-52-6793

Sales Branch Offices

Tokyo, Nagoya, Osaka, Hiroshima, Fukuoka

YOKOGAWA CORPORATION OF AMERICA

Headquarters

2 Dart Road, Newnan, GA. 30265-1094 U.S.A.

Phone: +1-770-253-7000 Facsimile: +1-770-251-0928

Sales Branch Offices / Texas, Chicago, Detroit, San Jose

YOKOGAWA EUROPE B. V.

Headquarters

Databankweg 20, 3821 AL Amersfoort THE NETHERLANDS

Phone: +31-334-64-1611 Facsimile: +31-334-64-1610

Sales Branch Offices / Houten (The Netherlands), Wien (Austria), Zaventem (Belgium), Ratingen (Germany), Madrid (Spain), Bratislava (Slovakia), Runcorn (United Kingdom), Milano (Italy), Velizy villacoublay(France), Johannesburg(Republic of South Africa)

YOKOGAWA AMERICA DO SUL S.A.

Headquarters & Plant

Praca Acapulco, 31-Santo Amaro, Sao Paulo/SP, BRAZIL CEP-04675-190

Phone: +55-11-5681-2400 Facsimile: +55-11-5681-4434

YOKOGAWA ENGINEERING ASIA PTE. LTD.

Head office

5 Bedok South Road, Singapore 469270 SINGAPORE

Phone: +65-6241-9933 Facsimile: +65-6241-2606

YOKOGAWA ELECTRIC KOREA CO., LTD.

Seoul Sales office

395-70, Shindaebang-dong, Dongjak-gu, Seoul,156-010, KOREA

Phone: +82-2-3284-3000 Facsimile: +82-2-3284-3019

YOKOGAWA TAIWAN CORPORATION

Head office

17F, No.39, Sec. 1, Chung Hwa Road Taipei, 100 TAIWAN

Phone: +886-2-2314-9166 Facsimile: +886-2-2314-9918

YOKOGAWA AUSTRALIA PTY. LTD.

Head office

Centrecourt D1, 25-27 Paul Street North, North Ryde, N. S. W. 2113, AUSTRALIA

Phone: +61-2-9805-0699 Facsimile: +61-2-9888-1844

YOKOGAWA INDIA LTD.

Head office

40/4 Lavelle Road, Bangalore, 560 001, INDIA

Phone: +91-80-227-1513 Facsimile: +91-80-227-4270

LTD. YOKOGAWA ELECTRIC

Grokholskiy per. 13, Build. 2, 4th Floor, 129010, Moscow, RUSSIA FEDERATION

Phone: +7-095-737-7868 Facsimile: +7-095-737-7869
